



ΣΥΛΛΟΓΗ

ΓΥΑΛΙΩΝ

ΠΡΟΣΤΑΣΙΑΣ



Fog prevention for optical clarity

Multi-length adjustment

Precision molded for comfort

Resists chemical corrosion,
shields from impact

BUILT FOR IT.™

A SCIENTIFICALLY-DESIGNED LIGHT & FLEXIBLE
MAINFRAME FOR ALL-DAY COMFORT & PERFORMANCE.
INTELLIGENT POLYMER MATERIALS ARE RESISTANT
TO WEAR, HEAT & FLEX.

PLANO SAFETY.

CAT DURABLE PROTECTIVE EYEWEAR

tools4all

ICONIC. DURABLE.

CAT EYEWEAR IN XL FIT

SAFETY
SUN
OPTICAL

Cat® Safety Eyewear

Many eye injuries occur when glasses are lifted to get a closer look – that's why **clarity of vision** through your protective eyewear is crucial. Keep them on throughout the job!

Cat® safety eyewear eliminates the reasons why you'd remove the frame. Anti-fog coatings and ventilation systems, anti-scratch and easy clean are all features that **enhance your visual experience**. Single hand lens angle adjustment means you don't have to remove the frame to alter the inclination.

As **a frame is only as good as its fit** and no two faces are alike, Cat frames are ergonomically **designed to flex-fit your individual facial shape**. Temple lengths and angles can be **individually adjusted**, and snap lock into position for security.

Cat frames offer **optimum protection**.

Polycarbonate lenses provide the ultimate ocular shield, locked in three directions to **resist impact** from front or side. Frame materials are tested to resist chemicals and impact from particles.

Cat has the **comfort and style** angle covered too. Looking good and feeling good in your eyewear increases wearability. Flexible materials offer a **pressure-free fit for continuous wear**. Tips and bridges are non-slip. Frames are lightweight.

Engineered to the core for total comfort, optimised reaction times and better risk assessment. Your clear vision ensures reduced risk of injury.

Cat safety eyewear meets and exceeds the following international standards for quality and safety:

CE EN 166:2001

ANSI Z87.1:2003

CSA Z94.3:2007

AS/NZS 1337.1:2010



The Cat logo, featuring the word "CAT" in a bold, black, sans-serif font with a stylized mountain peak above the "A", set against a yellow square background.

Lens is ultrasonically cleaned prior to fog prevention coating to maximise optical clarity

High comfort rubber tip composite

Treated in a purified and strictly dust-free environment

Multi-length adjustment with four locking positions

Rubber nose fit molded for comfort

Protective brow guard injected in strong and flexible nylon - this perfect finish resists corrosion, air pollution and continuous skin contact

Lenses tested for optical and mechanical perfection, impact and chemical resistance, high and low temperature response, and by coating analyser and abrasion tester to ensure quality.

Lens locks into housing for secure impact resistance

Hard coated both sides for resistance to scratching by fine particles, acids and solvents for ultra-clear vision

2.2mm polycarbonate lens material tested at velocity to shield from impact
Crystal clear optical class 1 lens for all models – distortion free vision, reduces eye fatigue and headaches - for continuous daily use

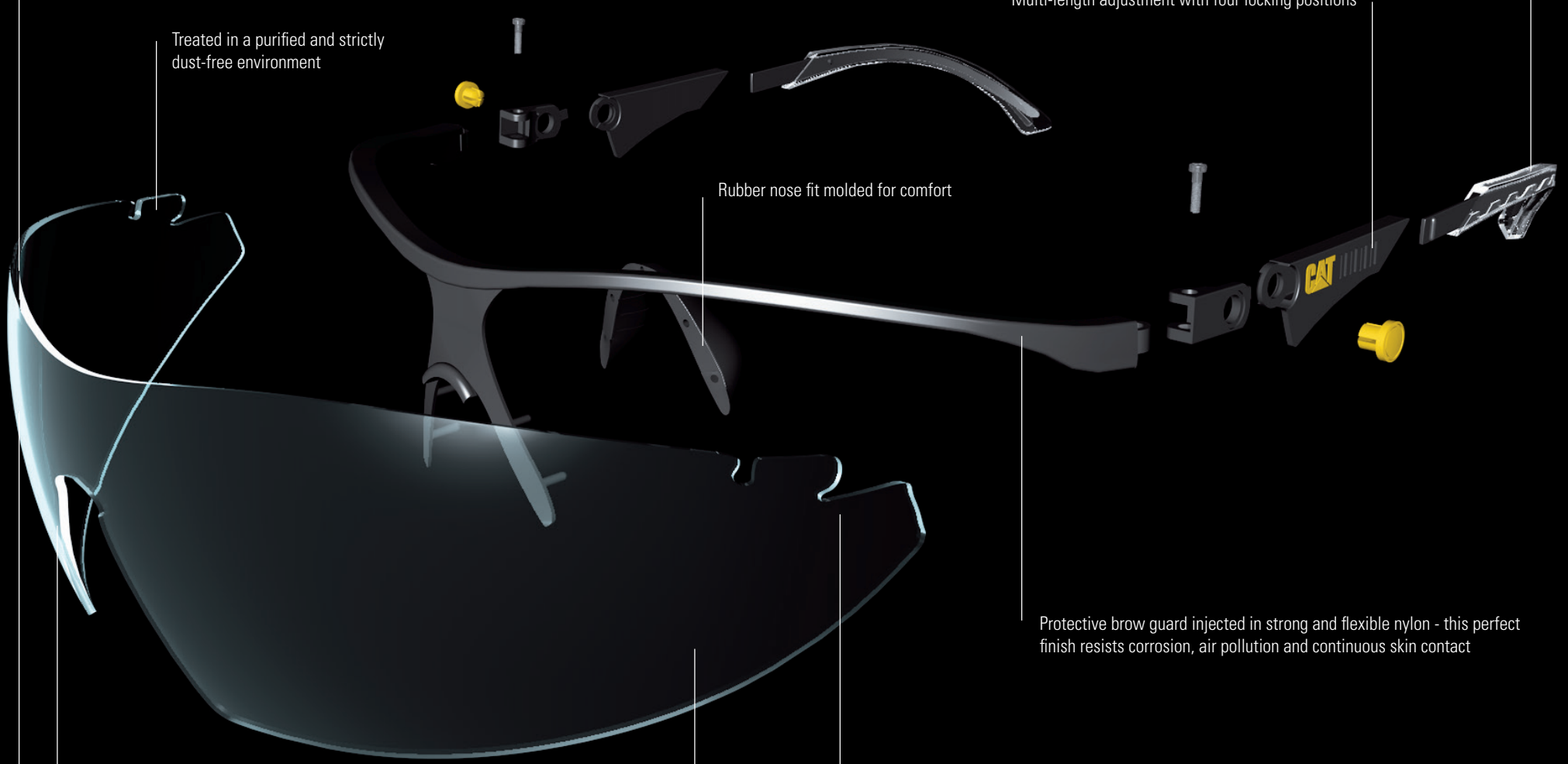

... your eyes

The eye is a fragile organ – a small fleck of dust can cause conjunctivitis, a solid particle at high speed can cause a perforation of the eye, the detachment of the retina, or permanent loss of sight.

Acute irritation of the eye and burns from chemicals and solvents can also cause partial to total loss of sight.

In the UK the department of Trade and Industry reports 120,000 accidents involving eye injuries every year. In the US 1000 work-related eye injuries occur every day. Over 10% of these result in a missed day of work. The majority of these come from foreign objects, blows, chemicals and cuts to the eye - which are all preventable by wearing the correct safety eyewear.

Cat safety eyewear meets and exceeds the following international standards for quality and safety:

CE EN 166:2001
ANSI Z87.1:2003
CSA Z94.3:2007
AS/NZS 1337.1:2010

The standards scientifically prove that all Cat frames:

- Withstand extreme pressures of heat and cold
- Resist mass impact at velocity
- Shield against chemical splash
- Provide excellence in optical quality including resilience to UV and other harmful rays

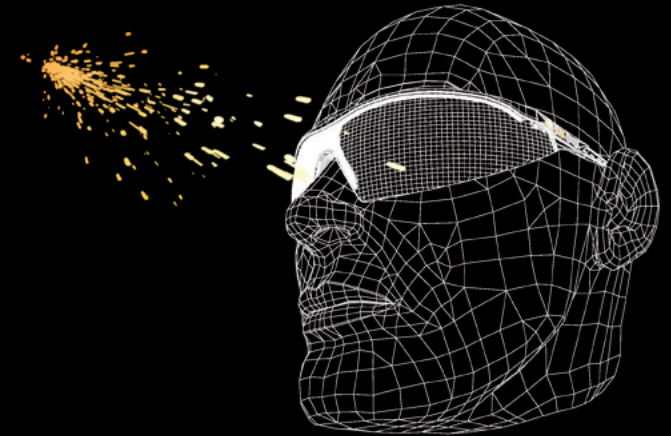

CAT[®]

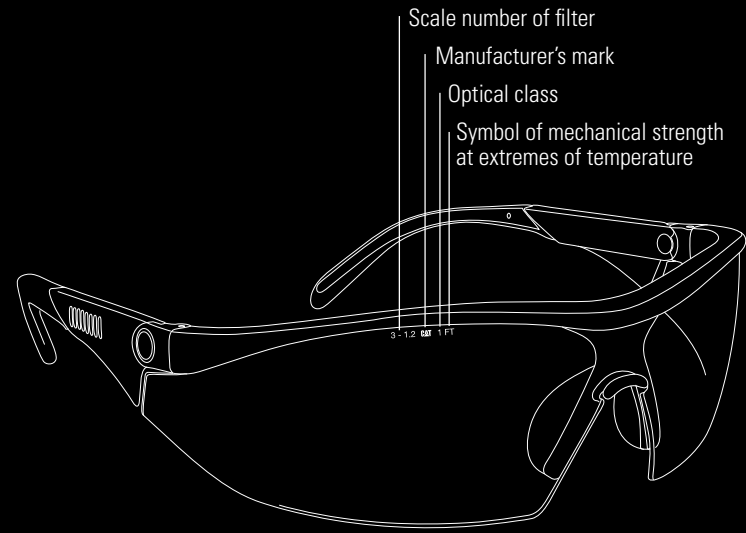
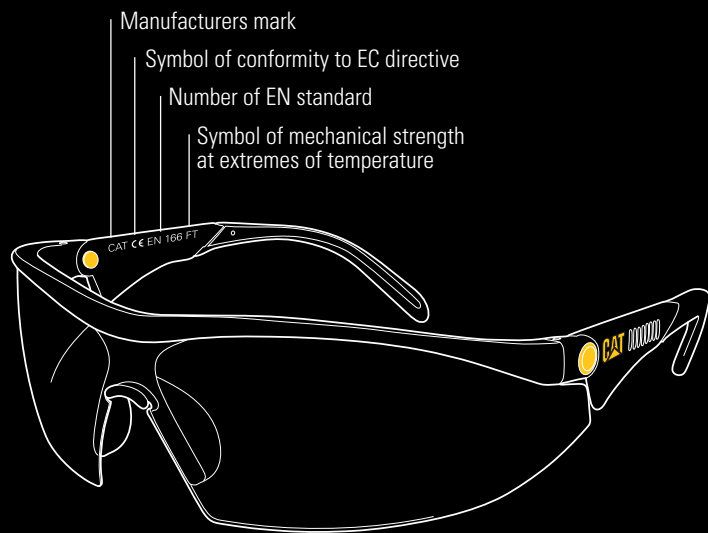
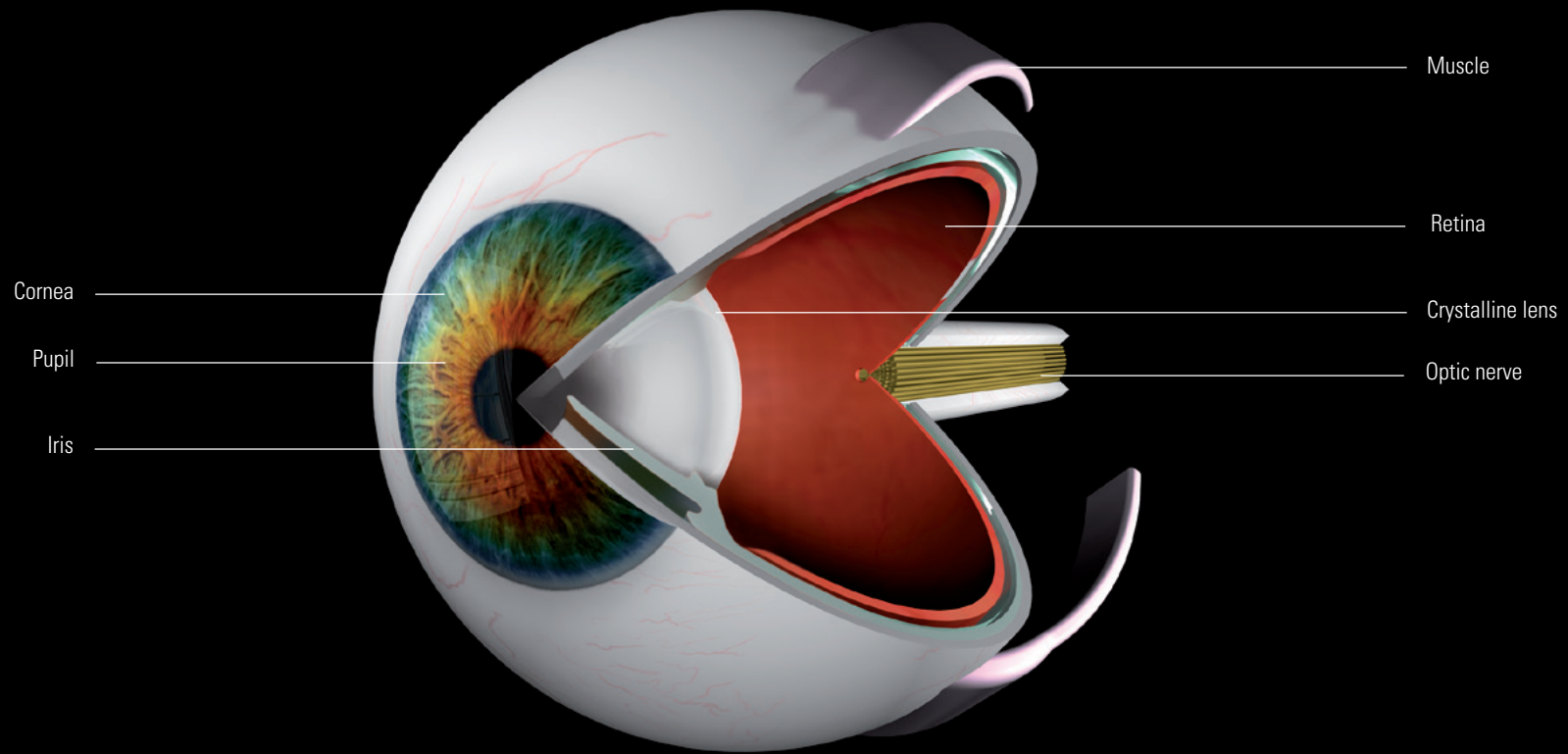



Fog prevention for optical clarity

Multi-length adjustment

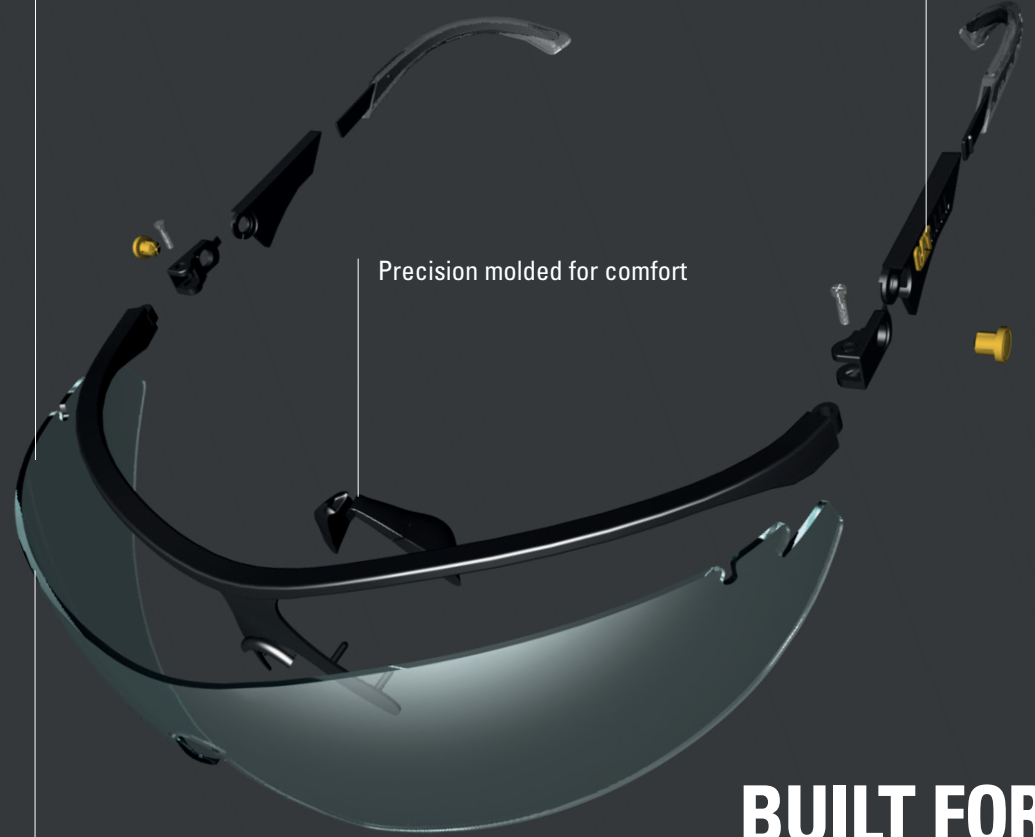

Precision molded for comfort

Resists chemical corrosion,
shields from impact

BUILT FOR IT.™

A SCIENTIFICALLY-DESIGNED LIGHT & FLEXIBLE
MAINFRAME FOR ALL-DAY COMFORT & PERFORMANCE.
INTELLIGENT POLYMER MATERIALS ARE RESISTANT
TO WEAR, HEAT & FLEX.

PLANO SAFETY.

CAT DURABLE PROTECTIVE EYEWEAR

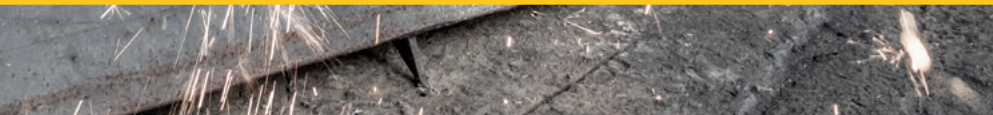

DIGGER



LENS SPECIFICATION

- lens inclination adjustment with snap-lock ratchet mechanism
- single wraparound 180 degree lens
- 2mm polycarbonate material tested at velocity to shield from impact
- crystal clear optical class 1 lens recommended for continuous wear
- fog prevention coating
- hard coated both sides for resistance to scratching

FRAME CHASSIS

- protective brow guard injected in buff polished nylon
- multi-length temple adjustment with 4 locking positions
- high comfort PVC tip composite
- PVC nose fit molded for comfort

Weight - 26g / 0.917oz

LENS COLORS

Digger -100

Clear - filter category 2C-1.2

Digger -103

Brown - filter category 5-2.5

Digger -104

Smoke - filter category 5-2.5

Digger -105

Blue Mirror - filter category 5-2.5

Digger -112

Yellow - filter category 2-1.2

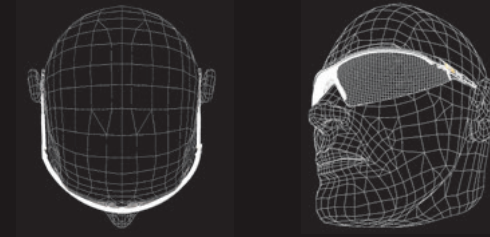
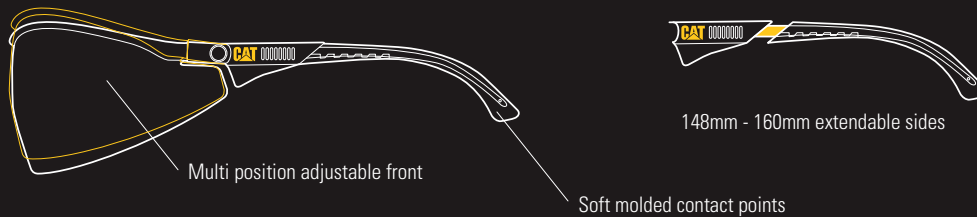
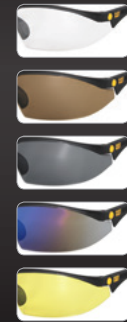

Universal wrap fit designed around different face shapes

SHIELD



LENS SPECIFICATION

- high wrap molded lens for upper and lower protection
- 2.4mm polycarbonate material tested at velocity to shield from impact
- crystal clear optical class 1 lens recommended for continuous wear
- hard coated both sides for resistance to scratching

FRAME CHASSIS

- universal fit
- polycarbonate temples
- color coded integrated nose fit

Weight - 26g / 0.917oz

LENS COLORS

Shield -100

Clear - filter category 2C-1.2

Shield -104

Smoke - filter category 5-2.5

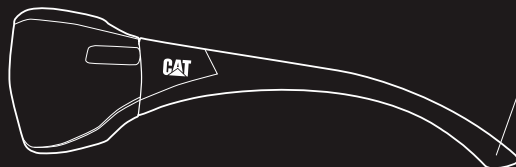

Lightweight polycarbonate construction

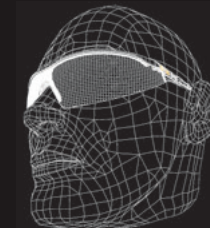
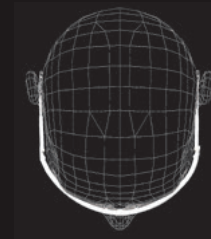

Universal wrap fit designed around different face shapes

GRIT



LENS SPECIFICATION

- high wrap molded lens for upper and lower protection
- polycarbonate material tested at velocity to shield from impact
- crystal clear optical class 1 lens recommended for continuous wear
- fog prevention coating
- hard coated both sides for resistance to scratching

FRAME CHASSIS

- sleek modern design
- injected rubber temples
- Rubber nose pads for comfort

Weight - 28g / 0.987oz

LENS COLORS

Grit -104

Smoke - filter category 5-2.5

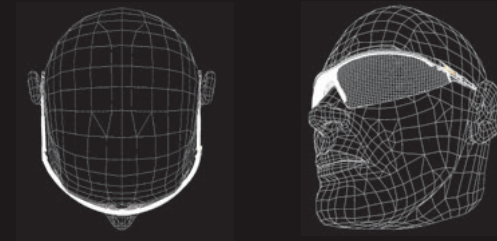
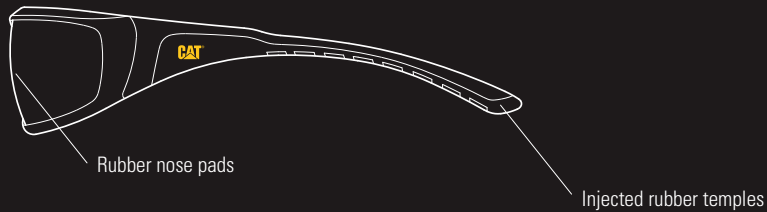

Universal wrap fit designed around different face shapes

BLAZE



LENS SPECIFICATION

- high wrap molded lens for upper and lower protection
- polycarbonate material tested at velocity to shield from impact
- crystal clear optical class 1 lens recommended for continuous wear
- fog prevention coating
- hard coated both sides for resistance to scratching

FRAME CHASSIS

- universal fit
- polycarbonate temples co-injected with rubber
- reflective sides to ensure high visibility



Weight - 27g / 0.952oz

LENS COLORS

Blaze -100

Clear - filter category 2C-1.2

Blaze -112

Yellow - filter category 2-1.2

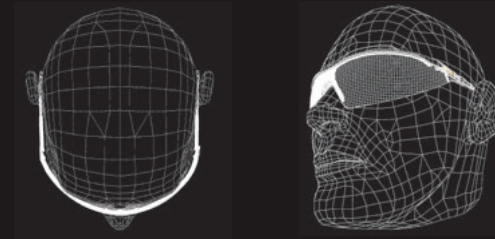
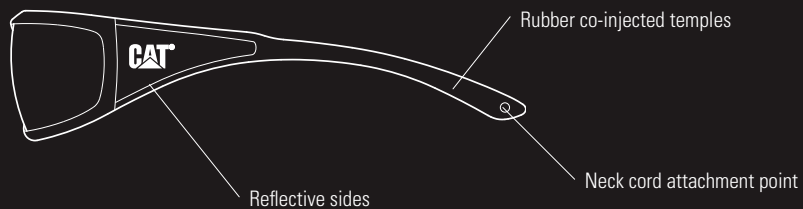

Universal wrap fit designed around different face shapes

DOZER



LENS SPECIFICATION

- four lens inclination adjustments with snap-lock ratchet mechanism
- single wraparound 180 degree lens
- 2.2mm polycarbonate material tested at velocity to shield from impact
- crystal clear optical class 1 lens recommended for continuous wear
- fog prevention coating
- hard coated both sides for resistance to scratching

FRAME CHASSIS

- multi-length temple adjustment with 4 locking positions
- high comfort PVC tip composite
- Rubber nose fit soft-molded for comfort

Weight - 24g / 0.846oz

LENS COLORS

Dozer -100

Clear - filter category 2C-1.2

Dozer -103

Brown - filter category 5-2.5

Dozer -104

Smoke - filter category 5-2.5

Dozer -105

Blue Mirror - filter category 5-2.5

Dozer -112

Yellow - filter category 2-1.2

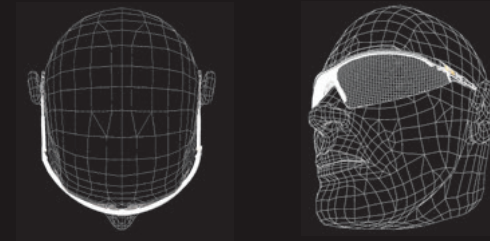
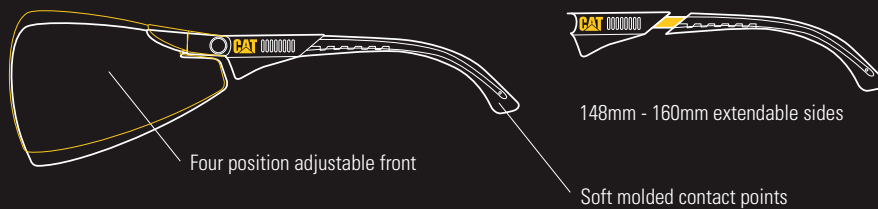

Universal wrap fit designed around different face shapes

TREAD



LENS SPECIFICATION

- three lens inclination adjustments with snap-lock ratchet mechanism
- 2.2mm polycarbonate material tested at velocity to shield from impact
- crystal clear optical class 1 lens recommended for continuous wear
- fog prevention coating
- hard coated both sides for resistance to scratching

FRAME CHASSIS

- flex temples with integrated cushioning system
- neck cord attachment facility
- upper and lower eye protection, vented for air flow and fog resistance
- soft touch vented nose piece

Weight - 29g / 1.02oz

LENS COLORS

Tread -100

Clear - filter category 2C-1.2

Tread -103

Brown - filter category 5-2.5

Tread -104

Smoke - filter category 5-2.5

Tread -105

Blue Mirror - filter category 5-2.5

Tread -112

Yellow - filter category 2-1.2

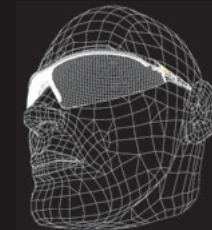
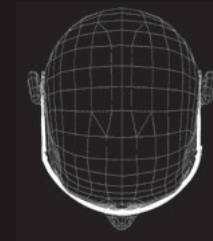
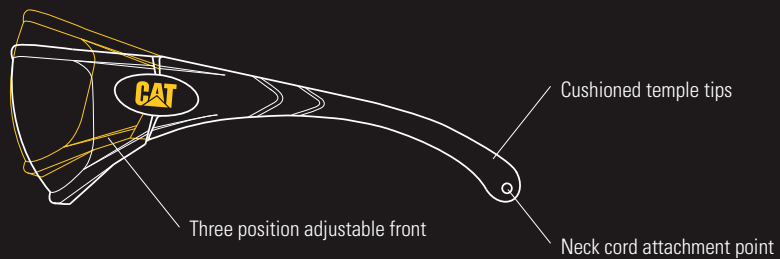
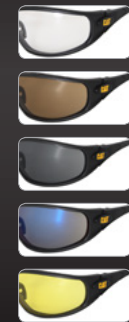

Universal wrap fit designed around different face shapes

DON'T LET YOUR GUARD DOWN

WHEN IT COMES TO EYE PROTECTION

PROTECTIVE EYEWEAR CAN PREVENT MORE
THAN 90% OF SERIOUS EYE INJURIES.



TRACK



LENS SPECIFICATION

- high wrap molded lens for upper and lower protection
- 2.4mm polycarbonate material tested at velocity to shield from impact
- crystal clear optical class 1 lens recommended for continuous wear
- fog prevention coating
- hard coated both sides for resistance to scratching

FRAME CHASSIS

- universal fit
- polycarbonate temples co-injected with soft tips
- high comfort PVC tip composite
- color coded integrated nose fit

Weight - 25g / 0.881oz

LENS COLORS

Track -100

Clear - filter category 2C-1.2

Track -103

Brown - filter category 5-2.5

Track -104

Smoke - filter category 5-2.5

Track -105

Blue Mirror - filter category 5-2.5

Track -112

Yellow - filter category 2-1.2

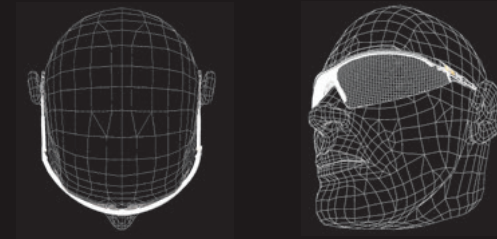
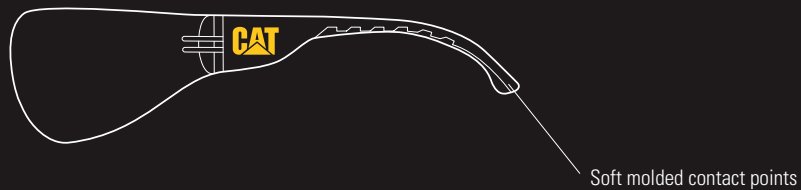
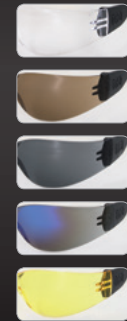

Universal wrap fit designed around different face shapes



LENS SPECIFICATION

- 100% optical lens clarity
- anti-scratch protection

FRAME CHASSIS

- lightweight and durable polycarbonate chassis
- designed for small faces
- ultra-lightweight wrap design for added comfort

Weight - 18g / 0.634oz

LENS COLORS

Jet -100

Clear - filter category 2C-1.2

Jet -104

Smoke - filter category 5-3.1

Jet -172

Pale pink - filter category 2-1.2

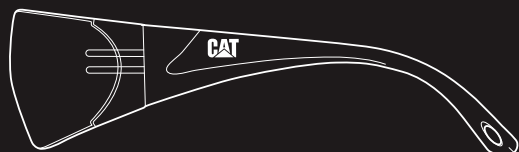

Lightweight polycarbonate construction

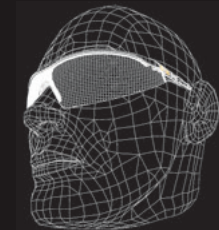
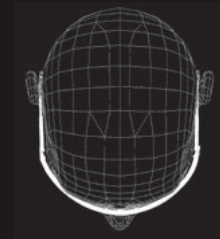

Universal wrap fit designed around different face shapes

TORQUE



LENS SPECIFICATION

- 100% optical lens clarity
- anti-scratch protection
- anti-fog protection

FRAME CHASSIS

- lightweight and durable nylon chassis with indirect ventilation
- soft foam lining for dust proof fit
- interchangeable, detachable temples
- interchangeable, detachable strap

Weight - 39g / 1.375oz (temple)

44g / 1.552oz (strap)

LENS COLORS

Torque -100

Clear - filter category 2C-1.2

Torque -104

Smoke - filter category 5-3.1

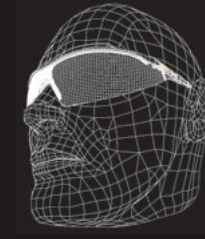
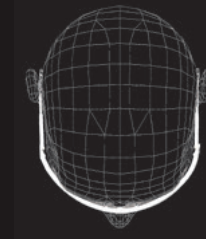
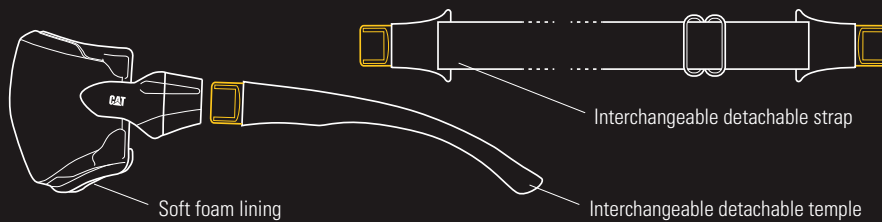

Universal wrap fit designed around different face shapes

GUARD



LENS SPECIFICATION

- 100% optical lens clarity
- anti-scratch protection
- anti-fog protection

FRAME CHASSIS

- lightweight and durable stainless steel chassis
- anti-slip rubber temple tips
- spring hinges
- anti-slip rubber nosepads

Weight - 39g / 1.375oz

LENS COLORS

Guard -100

Clear - filter category 2C-1.2

Guard -104

Smoke - filter category 5-3.1

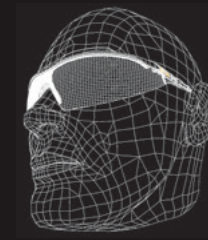
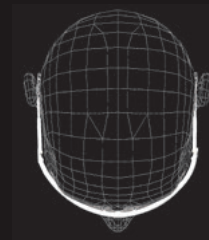

Universal wrap fit designed around different face shapes

REBEL



LENS SPECIFICATION

- high wrap molded lens for upper and lower protection
- 2.2mm polycarbonate material tested at velocity to shield from impact
- crystal clear optical class 1 lens recommended for continuous wear
- fog prevention coating
- hard coated both sides for resistance to scratching

FRAME CHASSIS

- double injection rubber temples
- universal fit
- soft touch temple tips for comfort fit
- soft muted ladies color

Weight - 25g / 0.88oz

LENS COLORS

Rebel -100

Clear - filter category 2C-1.2

Rebel -104

Smoke - filter category 5-2.5

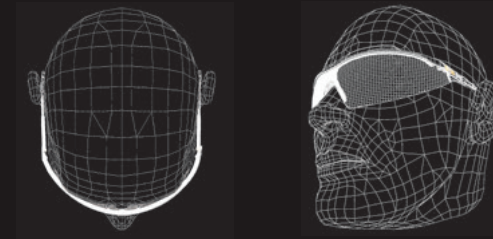

Universal wrap fit designed around different face shapes

