



# STAYER

- ES** Manual de instrucciones
- IT** Istruzioni d'uso
- GB** Operating instructions
- DE** Bedienungsanleitung
- FR** Instructions d'emploi
- P** Manual de instruções
- TR** Kullanma Kılavuzu
- PL** Instrukcja obsługi

**SC250W**  
**SC 250W PRO**  
**SC265W**  
**SC291W**  
**SC2500W**  
**SC2600W**  
**SLL265W**



## STAYER

Area Empresarial Andalucía - Sector I  
Calle Sierra de Cazorla nº7  
C.P: 28320 Pinto (Madrid) SPAIN  
Email: [info@grupostayer.com](mailto:info@grupostayer.com)

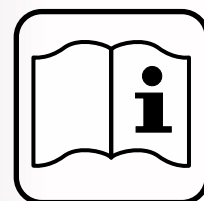

[www.grupostayer.com](http://www.grupostayer.com)

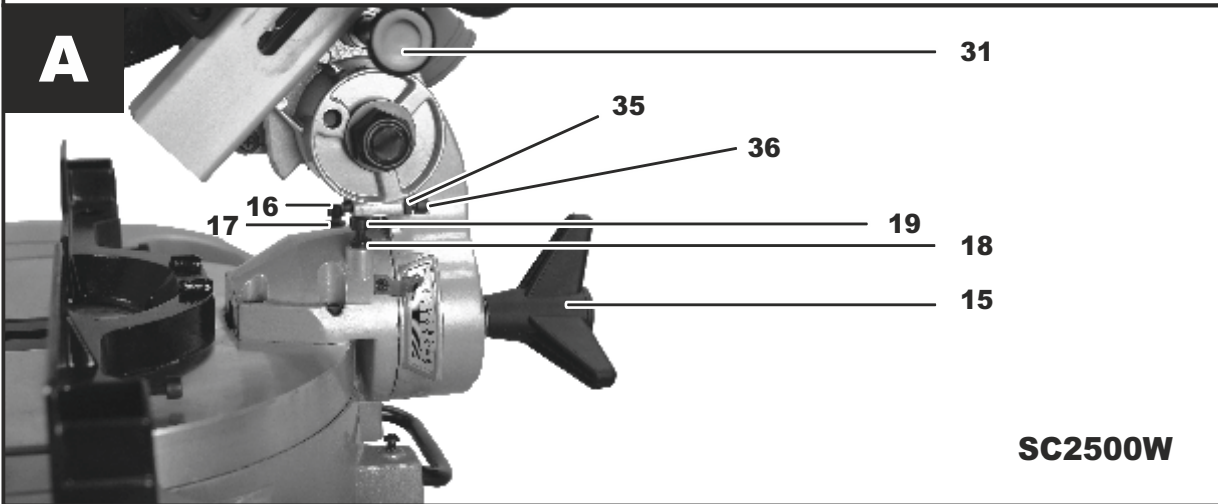
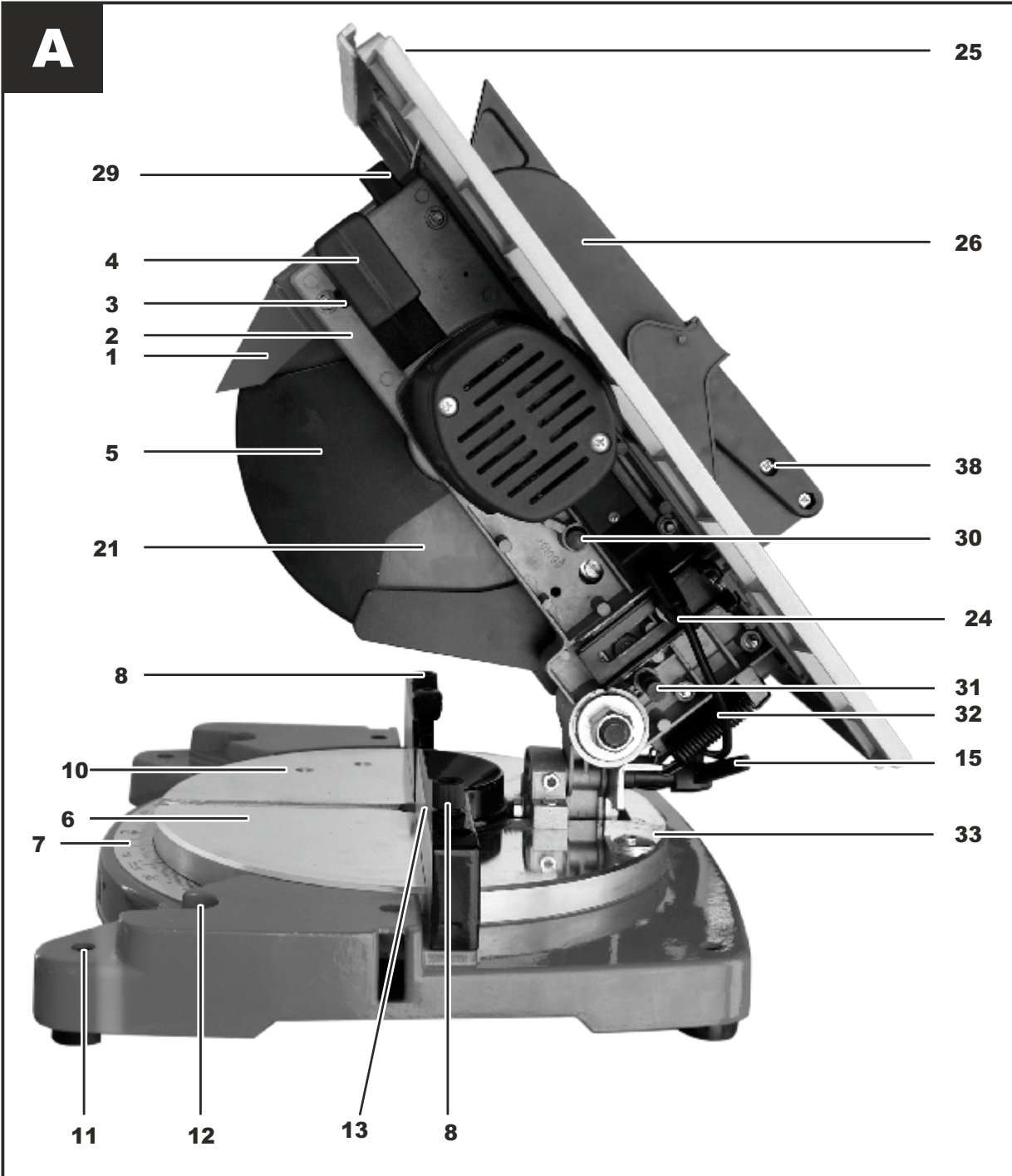

**B**

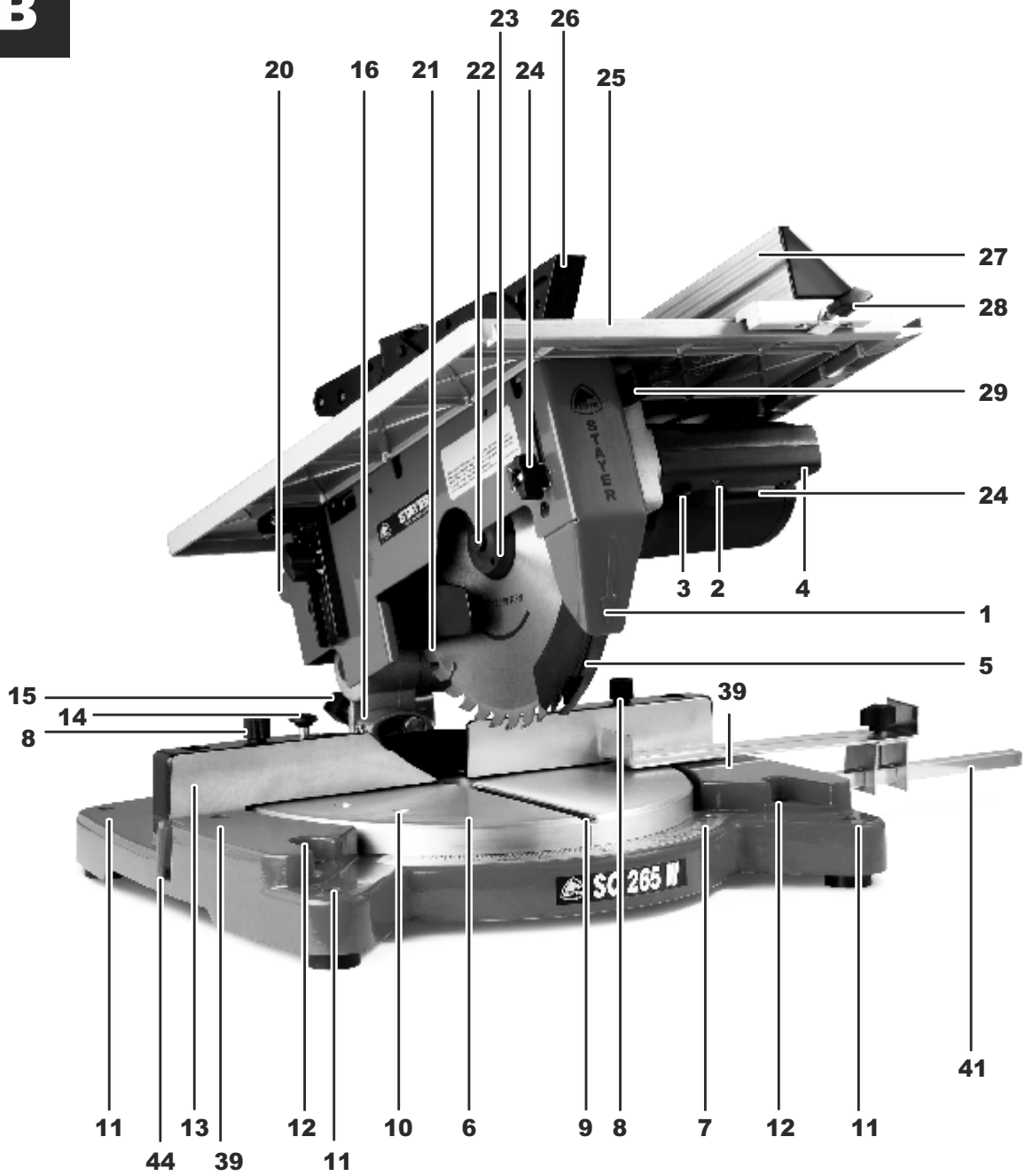

**B**

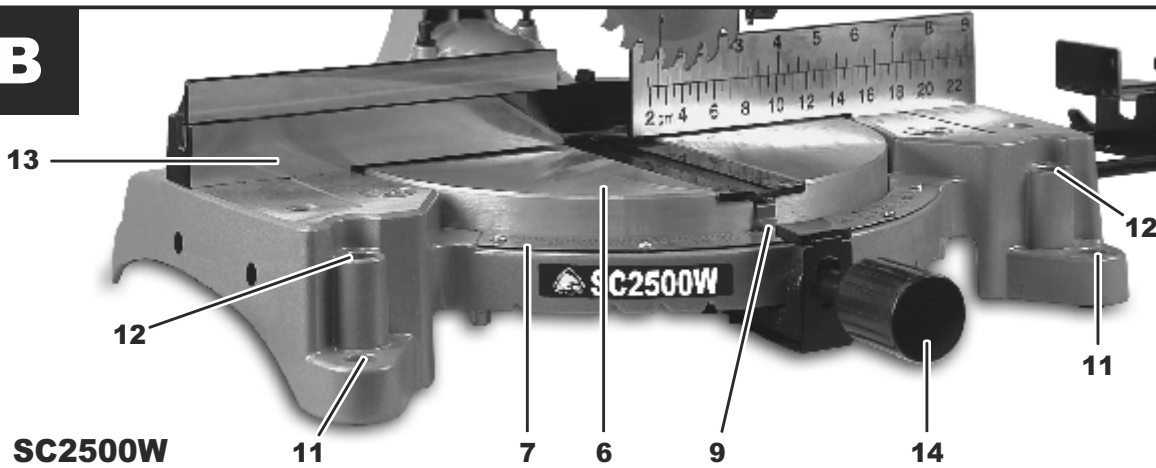

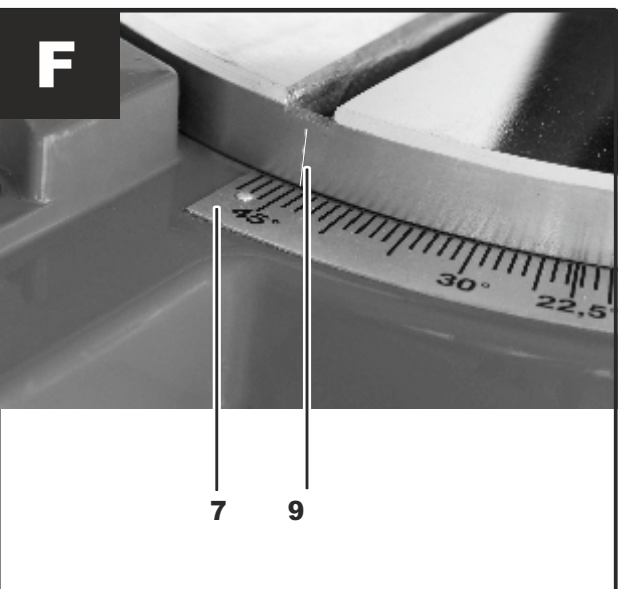
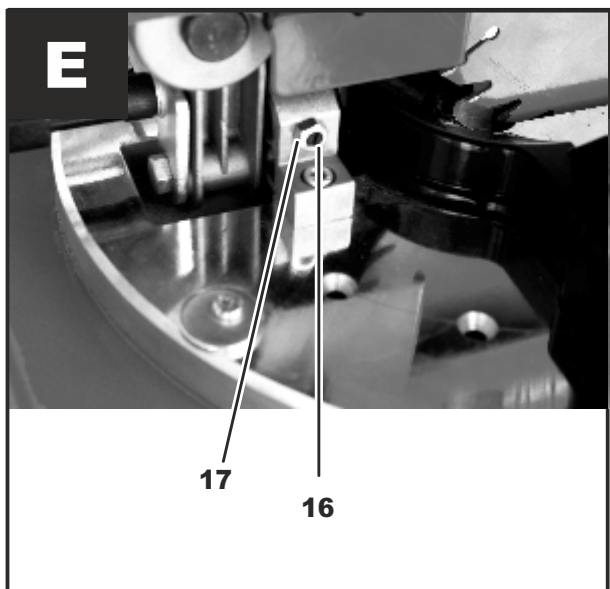
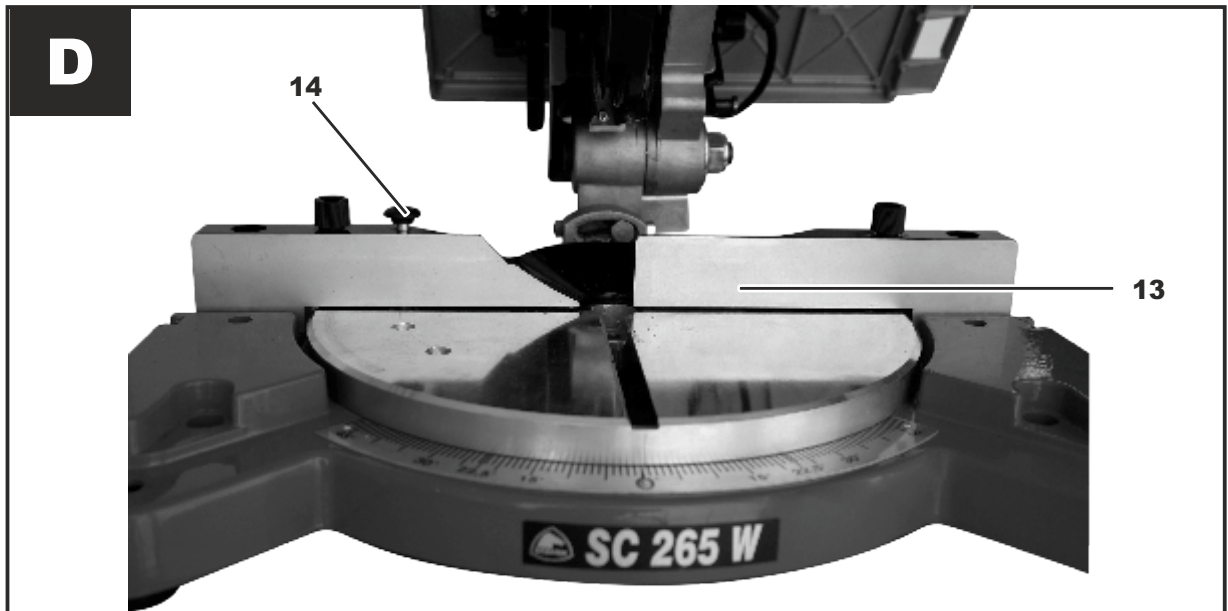
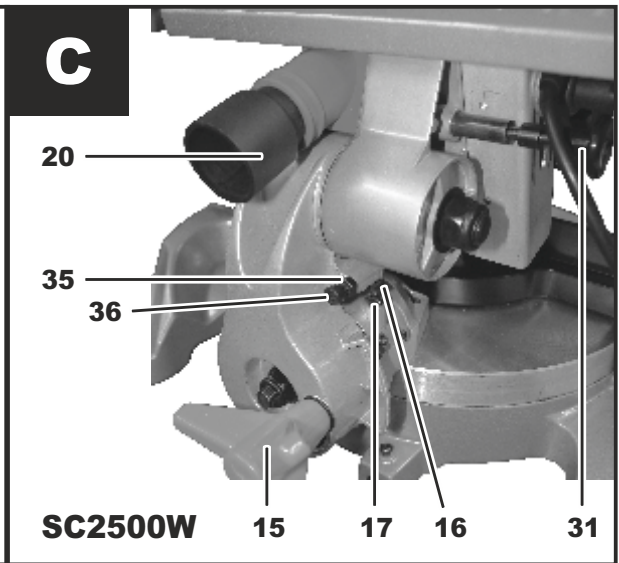
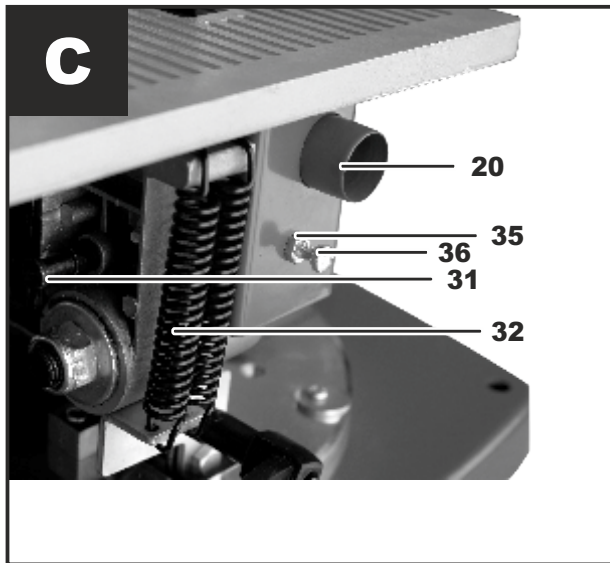



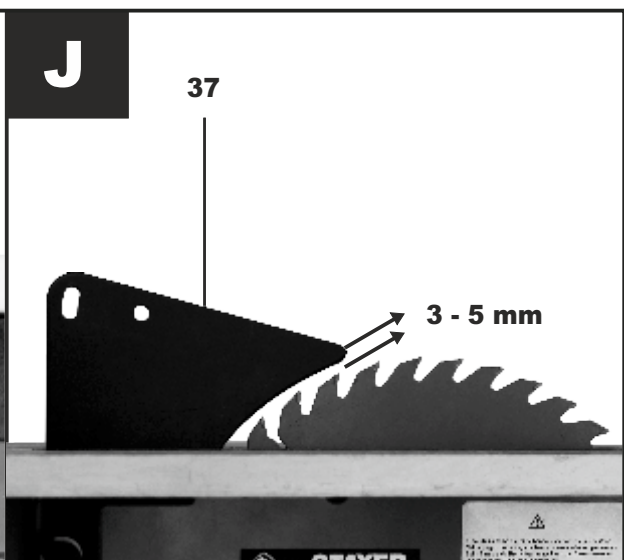
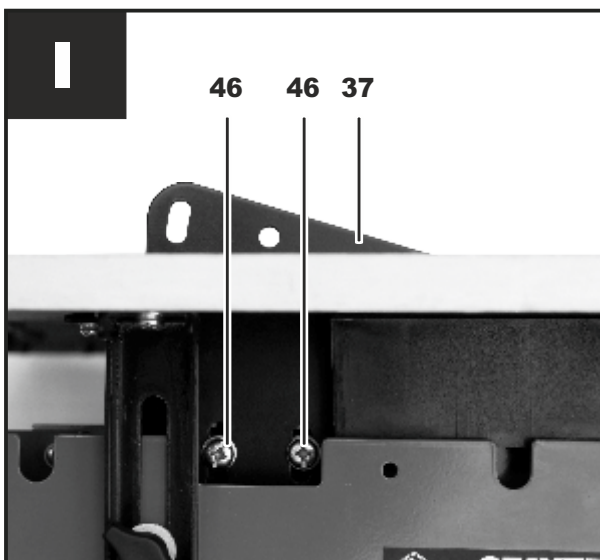
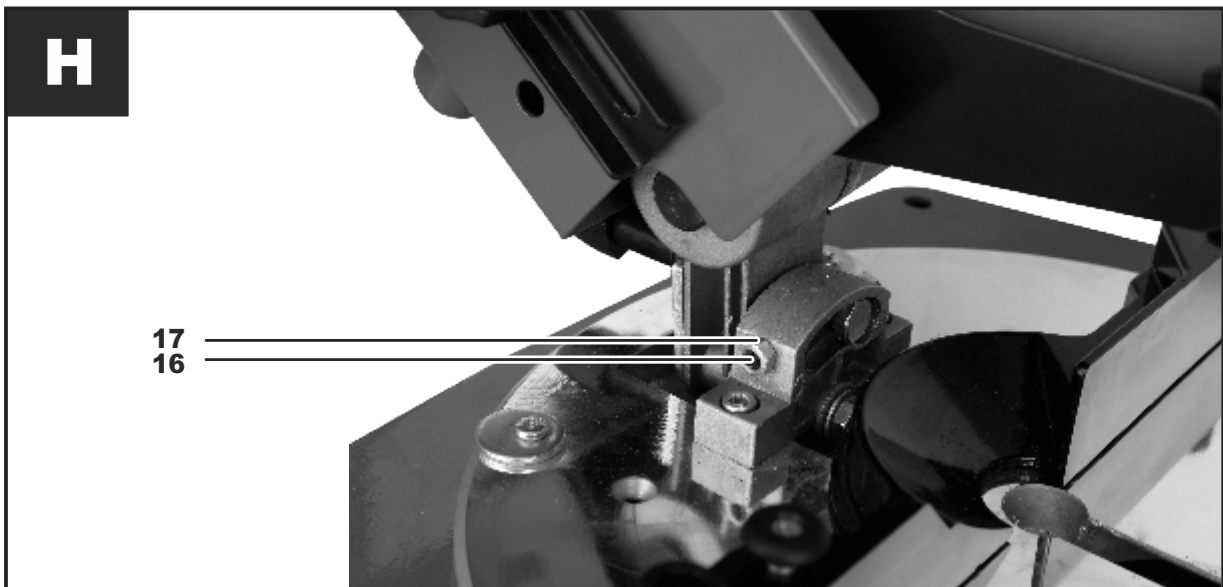
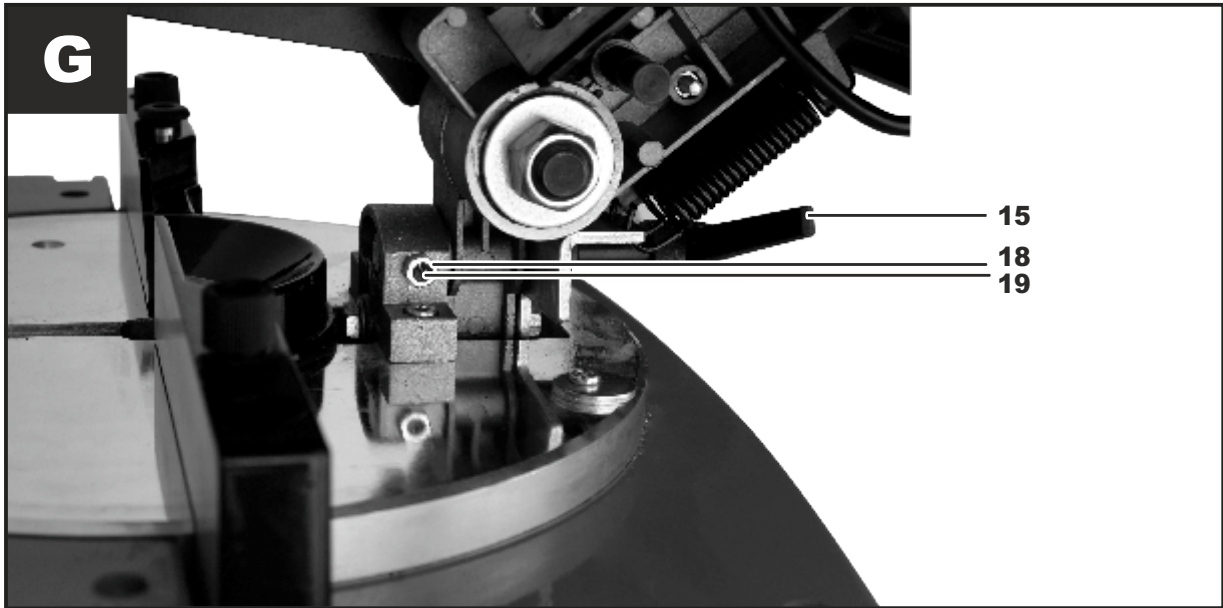

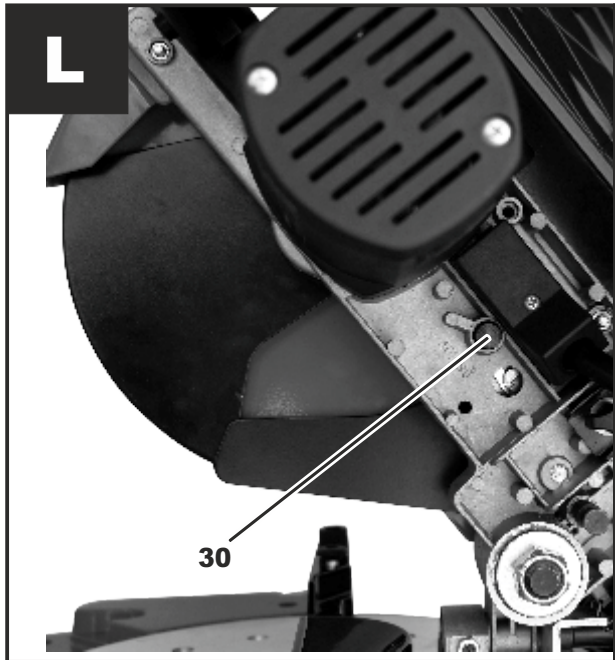
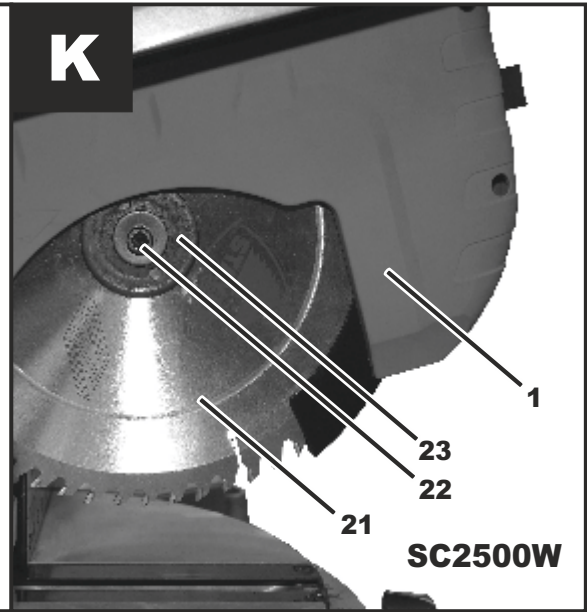
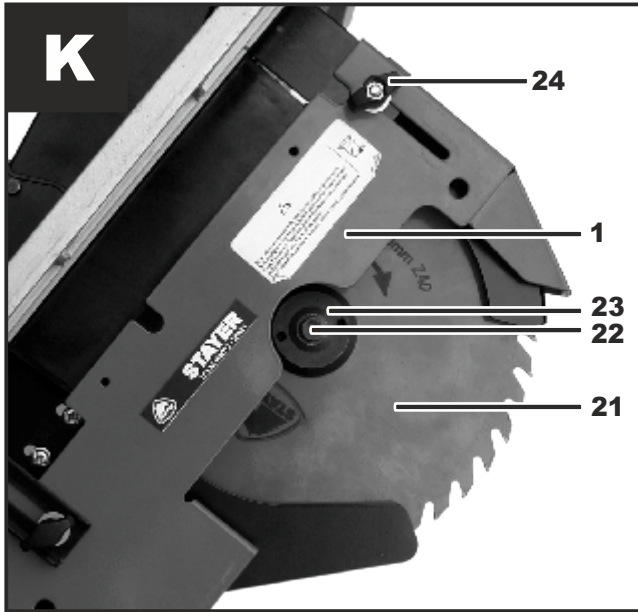

**M**

	Min	<b>1</b>	ALU	
		<b>2</b>	Cu Ni Zn	
		<b>3</b>		
		<b>4</b>		
	Max	<b>5</b>		

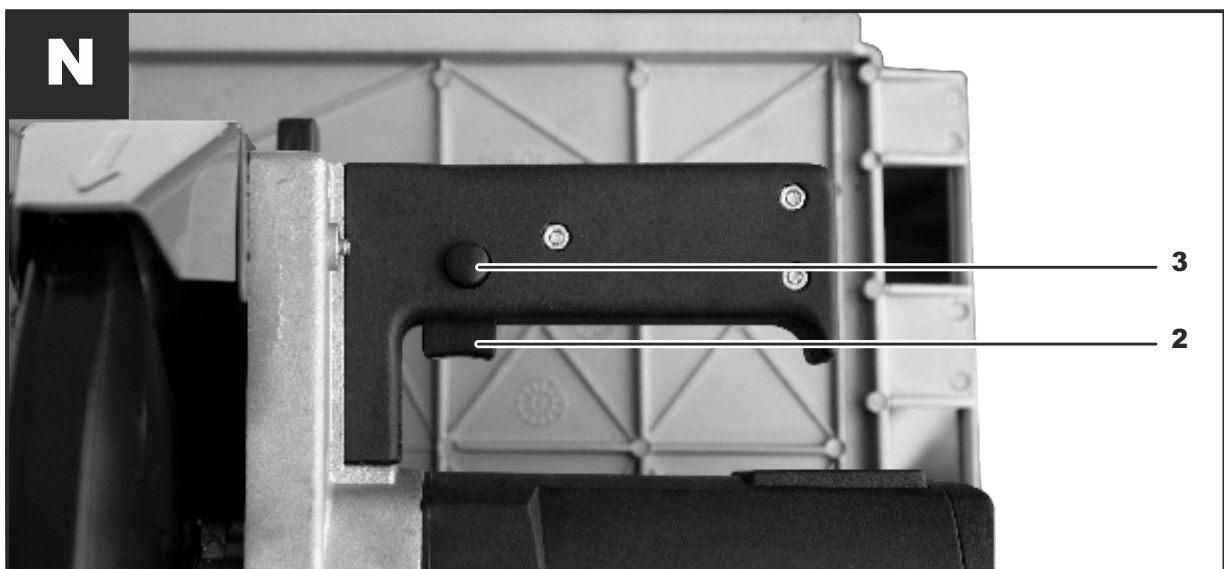

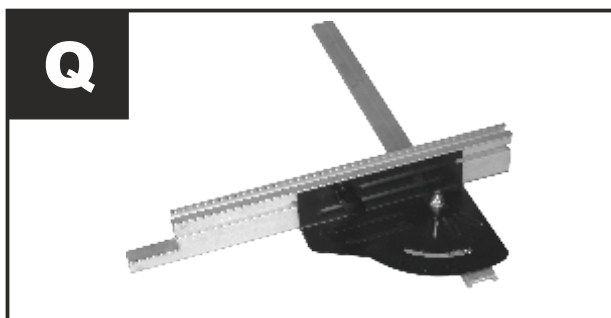
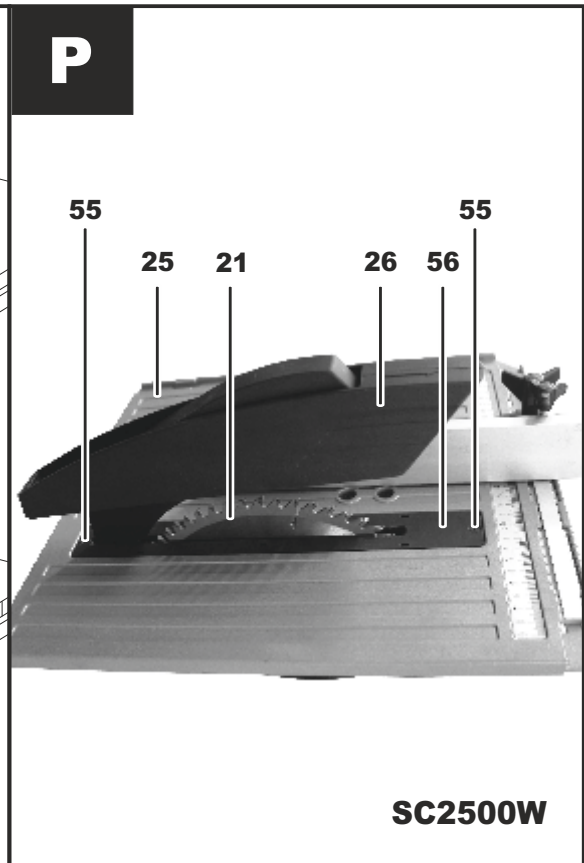
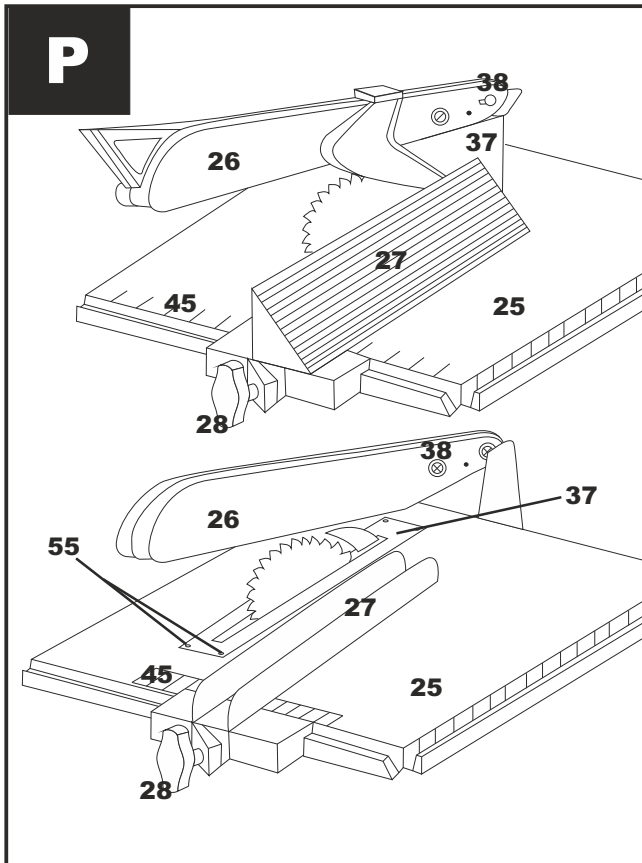
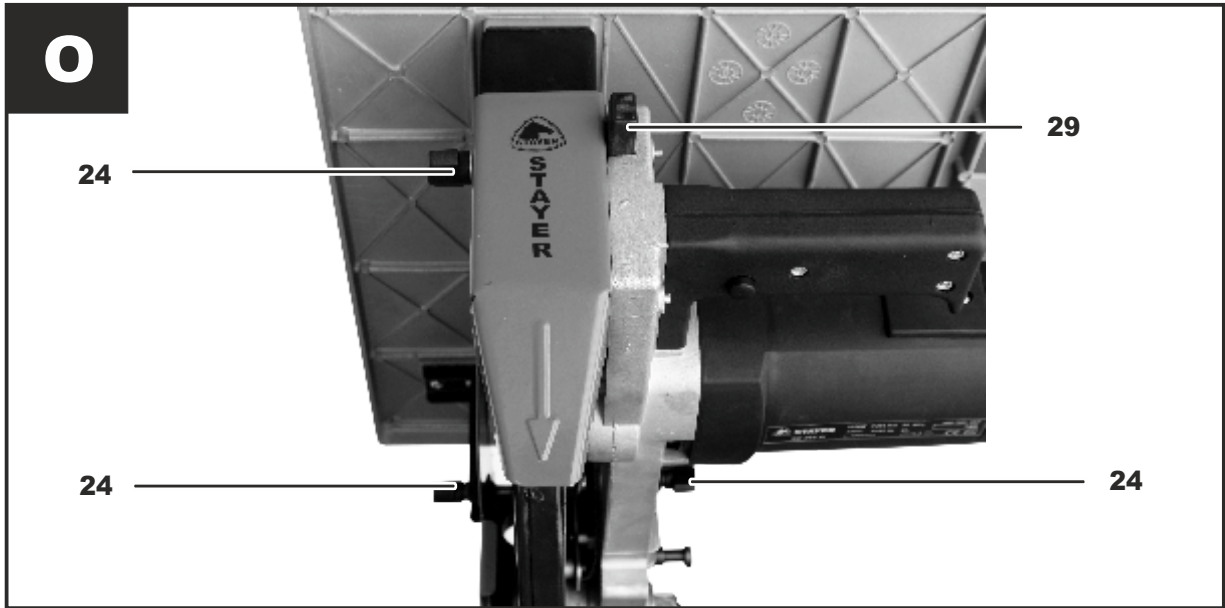

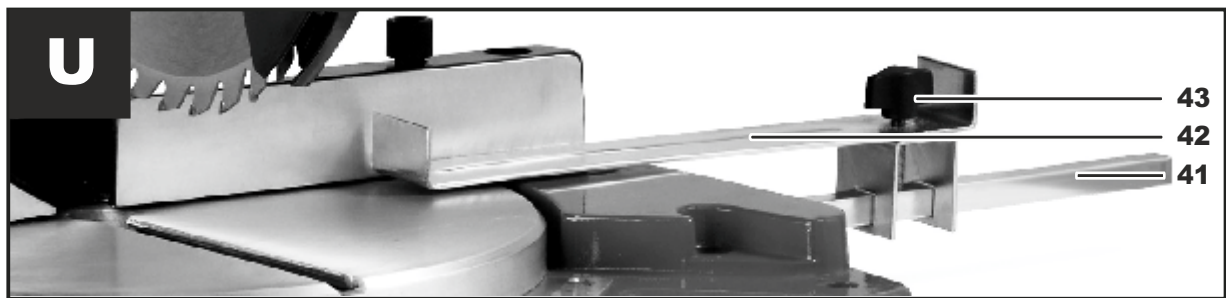
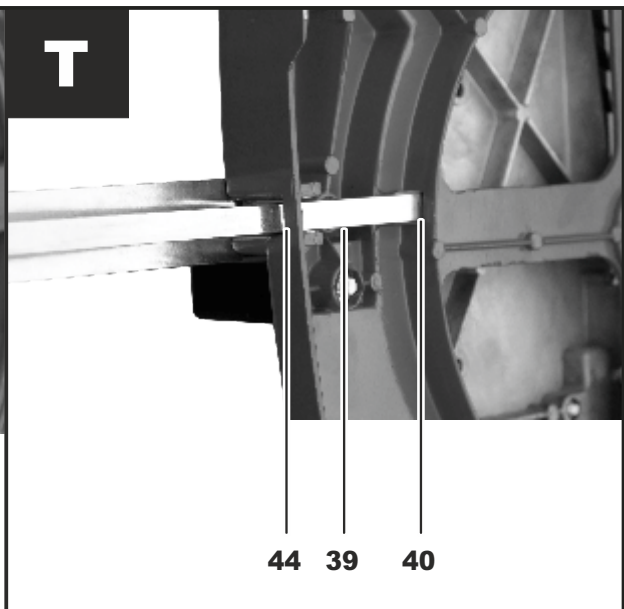
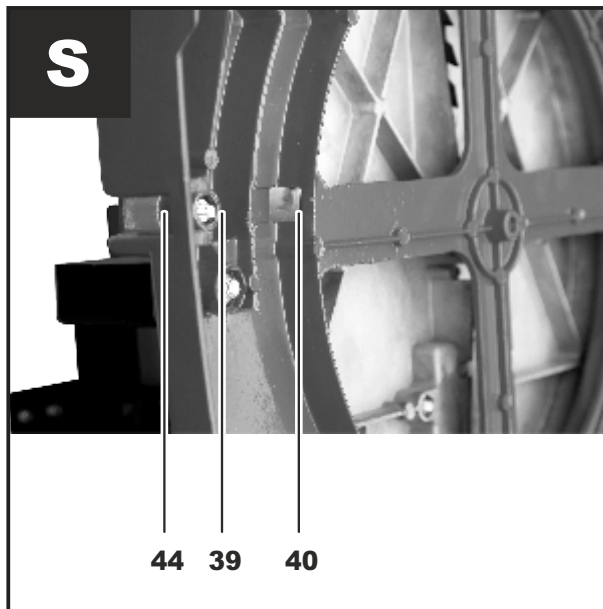
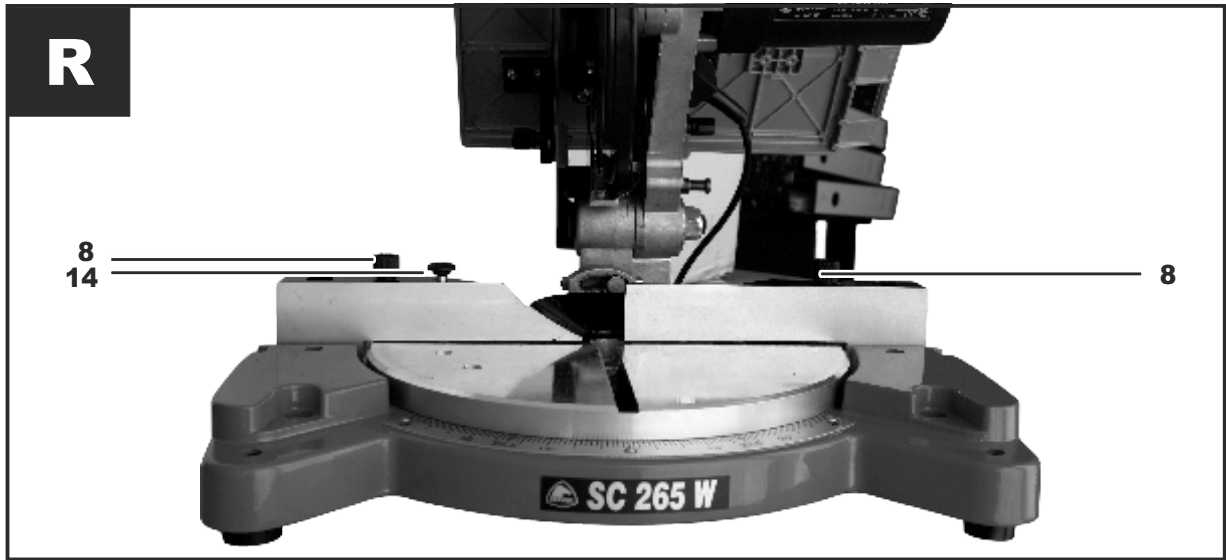



**V**



**W**

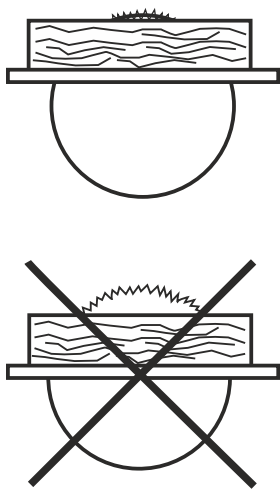

**X**

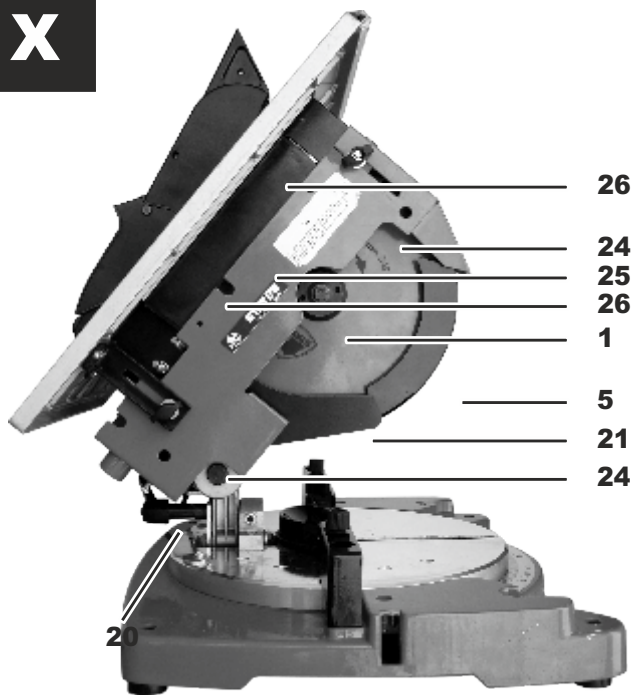

**Y**



**Z**

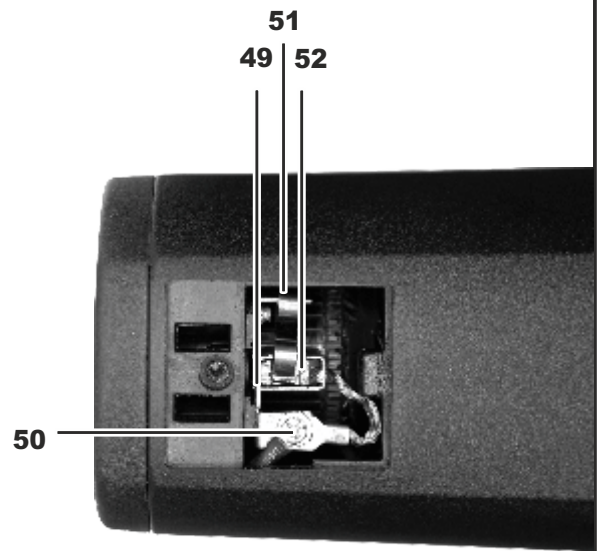
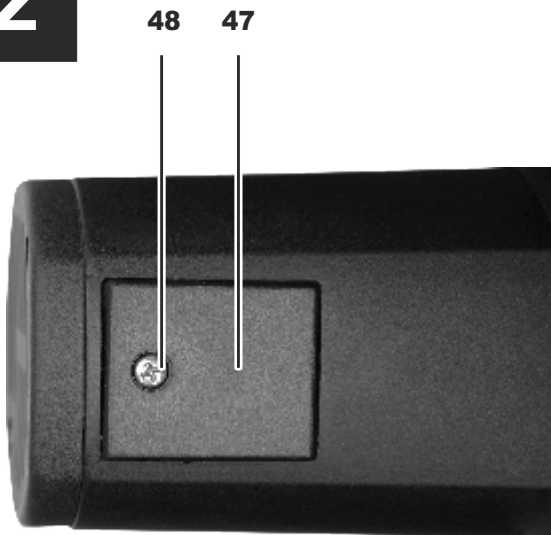

This manual is consistent with the date of manufacture of your machine, you will find information on the technical data of the machine acquired manual check for updates of our machines on the website:

[www.grupostayer.com](http://www.grupostayer.com)

## 1. Provided uses of the machine

This tool has been solely and exclusively provided for:

1. Stationary works on flat and stable surface
2. Working on hard and soft wooden pieces
3. Working on chipboard pieces
4. Working on fiberboard pieces
5. Working on PVC tubes
6. Making rectilinear cuts along the length and width of the workpiece
7. Making horizontal mitre-cuts between  $-45^\circ$  and  $45^\circ$ .

Making vertical mitre-cuts between  $90^\circ$  and  $45^\circ$

Refer to the limits regarding the size of the workpiece in corresponding chapter 11.

## 2. Unpackaging and assembling

### Unpackaging

1. Cut the seal and open the box.
2. Withdraw upper cardboard stoppers
3. Extract the box by firmly grasping the operating head and the motor body using both hands so as to balance the weight
4. Extract the box with the accessories
5. Extract the documentation
6. Preserve the cardboard box, the stoppers thereof and the documentation permanently in an inventoried safe environment being easily accessible and known to the machine operator.

### Packaging

#### IMAGES **A** **B** **V**

#### Operation 1: Securing, folding and fastening the operating head:

1. Place upper head at horizontally  $0^\circ$  acting on **8** or **14**.
2. Place upper head at vertically  $90^\circ$  acting on **15**.
3. Arrange protector **34** such that it contacts the cutting bench.
4. Fix protector **34** by means of the frontal wing nut **24**.
5. Push upper blocking button **29** to release the descent of the head.
6. Lower head to the limit and position it to be able to lock it with button **31**.
7. Push lower locking button **31** to lock the head.

#### Operation 2: Packaging the machine

1. Locate the cardboard box.
2. Locate documentation.

3. Firmly grasp the machine by its operating head and motor body.
4. Place the machine over the 4 circular recesses of the bottom of the box.
5. Store documentation of the machine.
6. Position upper cardboard stoppers.

Close the box and fix it with sealing tape.

## 3. Setting or fastening the machine in a stable position

1. The working area where the machine is being arranged must mandatorily be safe.
2. Support tool in a stable position on an even surface.
3. The base of the mitre saw has four holes for firmly fastening the machine to the working bench. It is strongly recommended to fix the machine to the bench by means of the pertinent screws and nuts.

## 4. Connection to the grid, wiring, fuses, socket type for the jack and requirements for grounding

1. For supplying electrical power to the machine, connect the Schuko Jack to a standard socket capable of supplying a minimum of 2500 VA.
2. The internal wiring of the machine is completely terminated so that no wiring is needed when installing it.
3. The machine does not have fuses although the use of a dedicated magnetothermal switch is recommended as a protection for the machine.
4. The machine has a class II electrical equipment so that it does not make use of the grounding of the electrical installation.

## 5. Illustrated description of functions

1. Casing
2. Connecting/disconnecting switch
3. Locking button for continuous operation
4. Grip
5. Tilttable guard hood
6. Lower cutting table
7. Scale for horizontal mitre angle
8. Horizontal locking button for discretionary mitre angles
9. Indicator for horizontal angles
10. Locking holes for fixed mitre angles
11. Machine fastening holes
12. Clamp anchor holes for fastening the workpiece
13. Stopper guide
14. Anchor bolt for horizontal locking for fixed mitre angles
15. Lever for vertical locking for discretionary mitre angles
16. Screw for vertical adjustment for fixed mitre angles at  $45^\circ$
17. Nut for vertical adjustment for fixed mitre angles at  $45^\circ$

18. Nut for vertical adjustment for fixed mitre angles at 0°
19. Screw for vertical adjustment for fixed mitre angles at 0°
20. Nozzle for expelling sawdust
21. Cutting disk
22. Saw blade fastening screw
23. Clamping flange
24. Wing nuts for adjusting the height of the upper table / fastening the lower guard
25. Upper cutting table
26. Movable guard of the upper table
27. Movable stopper guide of the upper table
28. Wing nut for adjusting the movable stopper guide of the upper table
29. Locking button for the upper resting position
30. Locking button for the tiltable guard hood
31. Locking button for the lower resting position
32. Counterweight spring for the cutting head
33. Adjustment cam for the indicator for horizontal angles
34. Stationary lower guard
35. Nut for retaining the adjustment of the locking in the lower position
36. Screw for adjusting the locking in the lower position
37. Keel of the upper table
38. Lock for the guard of the upper table
39. Fastening screw for the adjusting system for fixed-length cutting
40. Fastening wedge of the adjusting system for fixed-length cutting
41. Support for the adjusting system for fixed-length cutting
42. Adjustable stopper of the adjusting system for fixed-length cutting
43. Adjusting wing nut for the movable stopper guide of the upper table
44. Insertion hollow of the system for fixed-length cutting
45. Cutting length scale of the upper table
46. Keel height adjusting screw
47. Brush-holder lid
48. Fastening screw for the brush-holder cover
49. Brush-holder
50. Brush-holder connecting screw
51. Brush pressing spring
52. Brush
53. Horizontal head movement button.
54. Adjustment screws crankcase.
55. Cover fixing bolts of the keel top table.
56. Cover top table keel.

## 6. Limitations regarding environmental conditions

The IP degree of this machine is 20. This machine is protected against its dangerous parts being accessed by a finger and against solid foreign particles having diameters of 12'5 mm and more. This machine does not have any kind of protection against the entry of water so that its use in exterior or interior environmental conditions with a risk of precipitations is forbidden.

## 7. List of contents

1. Provided uses of the machine
2. Unpackaging and assembling
3. Setting or fastening the machine in a stable position
4. Connection to the grid, wiring, fuses, socket type for the jack and grounding conditions
5. Illustrated descriptions of functions
6. Limitations regarding environmental conditions
7. List of contents
8. Settings and testing
9. Changing tools
10. Fixing for operation
11. Limits regarding the workpiece size
12. General instructions for use
13. Precautions and working garment
14. Special safety precautions
15. Measures for preventing machine-specific risks
16. Dust extraction
17. General safety instructions
18. Regular cleaning, maintenance and greasing
19. Repair service by the manufacturer or commercial agent
20. List of parts that may be replaced by the user
21. Special tools as possibly required
22. Safe operation
23. Technical specifications
24. Warranty
25. Declaration of conformity

## 8. Settings and testing

### Warning!

Before any intervention on the electrical tool remove jack from power socket.

If the machine has been subject to prolonged or intense use, it must be checked and adjusted so as to ensure the machine's correct quality of service and safety.

This requires knowledge, experience and special tools. The official technical service of Stayer Iberica S.A. will carry out that work for you in a quick thorough and inexpensive manner.

### Adjusting the locking in the lower resting position

#### IMAGES



#### Checking

1. On starts from the machine being locked in the upper resting position.
2. Unlock by pressing button **29**.
3. Lower down to the lower stop by means of **4**. Press button **31**. If the bolt of the button is well adjusted, it must enter until abutting. Otherwise proceed to adjusting



## Adjusting

1. Loosen fastening screw **35**.
2. Lower the head down to the lower stop by means of **4**.
3. Tighten or loosen screw **36** until button **31** smoothly penetrates until abutting. Whilst retaining screw **36**, fasten screw **35**.

---

## Adjusting the horizontal mitre angle to $\pm 45^\circ$

---

### IMAGES



### Checking

1. Raise locking bolt **14** (**SC2500W**, Turn the locking knob **14** toward the left and press the button **53** to move the head).
2. Move the head horizontally until it locks at  $+45^\circ$  (**SC2500W/SC2600W** Rotate the knob **14** to adjust the head in the desired position).
3. Check that the indicator for horizontal angles marks exactly  $45^\circ$ . If not, proceed to adjusting.
4. Repeat the same sequence for the horizontal angle at  $-45^\circ$ .

### Adjusting

1. Keep locking bolt **14** raised.
2. Loosen fastening screw of cam **33**.
3. Move the whole of head and cutting table horizontally until it locks at  $45^\circ$ .
4. Turn cam **33** against guide **13** until indicator **9** coincides with the  $45^\circ$  marking of indicator **7**.
5. Tighten the fastening screw of cam **33**.
6. Release locking bolt **14**.
7. Repeat the same sequence for the horizontal angle at  $45^\circ$ .

### Adjustment for SC2500W / SC2600W

1. Turn the locking knob **14** to the left, and click the button **53** to move the head.
2. Horizontally move the head assembly and cutting table up to 45 degrees.
3. Release the button **53** of the locking knob **14** and turn right to secure.
4. Repeat the same sequence for the horizontal angle of  $-45$  degrees.

---

## Adjusting the vertical mitre angle to $90^\circ$

---

### IMAGES



### Checking

1. Release vertical adjustment of the head by loosening control element or nut **15** (with Allen key).
2. Move head to the right stopper ( $90^\circ$ ).

3. Lock the vertical adjustment of the head by tightening control element or nut **15** (with Allen key).
4. Check the angle by means of a duly calibrated angle chart or a goniometer (minimum precision  $\pm 5^\circ$ ) applying one of the surfaces thereof on cutting table **6** and the other on cutting disk **21**.
5. Should the side of the angle chart not adjust exactly to the disk or if the direct measurement of the goniometer reached a deviation of more than  $\pm 20^\circ$ , proceed to adjusting.

### Adjusting

1. Release the vertical adjustment of the head by loosening control element or nut **15** (with Allen key).
2. Move the head to the right stop ( $90^\circ$ ).
3. Remove retainer nut **18**.
4. Place a goniometer (minimum precision  $\pm 5^\circ$ ) applying one of its sides on cutting table **6** and the other on cutting disk **21**.
5. Act on adjusting screw **19** until obtaining a measurement of  $90^\circ$ .
6. Fasten the adjustment by tightening retainer nut **18** whilst retaining screw **19** with a screwdriver so as to prevent it from moving.
7. Block the vertical adjustment of the head by tightening control element or nut **15** (with Allen key).

---

## Adjusting the vertical mitre angle to $45^\circ$

---

### IMAGES



### Checking

2. Release the vertical adjustment of the head by loosening control element or nut **15** (with Allen key)
3. Move head to the left stop ( $45^\circ$ ).
4. Block the vertical adjustment of the head by tightening the control element or nut **15** (with Allen key).
5. Check the vertical adjustment by means of a duly calibrated angle chart or a goniometer (minimum precision  $\pm 5^\circ$ ) applying one of its sides on cutting table **6** and the other on cutting disk **21**.
6. Should the side of the angle chart not adjust exactly to the disk or if the direct measurement of the goniometer reached a deviation of more than  $\pm 20^\circ$ , proceed to adjusting.

### Adjusting

1. Release the vertical adjustment of the head by loosening control element or nut **15** (with Allen key).
2. Move head to the left stopper ( $45^\circ$ ).
3. Remove retainer screw **17**.
4. Check the vertical adjustment by means of a duly calibrated angle chart or a goniometer (minimum precision  $\pm 5^\circ$ ) applying one of its sides on cutting table **6** and the other on cutting disk **21**.

5. Act on adjusting screw **16** until obtaining a measurement of 45° on the goniometer or until the surface of the angle chart that contacts the disk has full (it does not allow any light to pass through) contact.
6. Fasten the adjustment by tightening retainer screw **17** whilst retaining screw **16** with a screwdriver so as to prevent it from moving.
7. Block the vertical adjustment of the head by tightening control element or nut **15** (with Allen key).

### Adjusting the keel of the upper cutting table

#### IMAGES



#### Information!

1. You will need a slide gauge and a ruler (not included) to carry out this adjustment.

#### Checking

1. Remove the locking element **38** of the guard **26** of the upper table.
2. Tilt guard **26** backwards.
3. The distance between the inside of keel **37** and the outside of the teeth of the disk must be between 3mm and 5mm at any visible point. If the measurements are not within the range of the figure, proceed to adjusting.
4. The keel **37** must be perfectly aligned with the disc **21**. If not do not use the machine and take it to service.

#### Adjusting

1. Remove the locking element **38** of the guard **26** of the upper table.
2. Tilt guard **26** backwards.
3. Loosen the adjusting screws **46** of the keel.
4. Adjust the height of the keel in such a manner that the distance between the inside of keel **37** and the outside of the teeth of the disk must be between 3mm and 5mm at any visible point.
5. Tighten adjustment screws **46** of the keel.
6. Place the guard in its position.

## 9. Changing tools

#### Attention!

This operation must be carried out with the machine unplugged and with the disk still. Use protective gloves.

- Use obligatorily disk according to normative EN 847-1
- Use obligatorily disc thicker than the riving knife
- Use obligatorily the regulatory push stick and save it away if not use it.
- Use of fast steel disks prohibited (HSS)
- Use of defective or deformed prohibited
- Replace the table insert when worn

### Removal of the cutting disk

#### IMAGES



1. Place the head in its upper blocking position by tilting the head upwards until abutting.
2. Immobilize flange **23** by means of the flange wrench as delivered together with the equipment.
3. Loosen hexagon head screw **22** clockwise with the tubular key as delivered together with the equipment.
4. Tighten button **30** to unblock the movable guard **5**.
5. Clear guard **5** by pulling it upwards.
6. Hold the disc with one hand
7. Remove the flange and the hexagon head screw.
8. Remove the disk to be changed.

#### Only SC2500W

1. Place the head in its upper blocking position by tilting the head upwards until abutting.
2. Loosen the 5 screws **54** holding the casing **1**.
3. Loosen the 2 screws keel **55** of the top **56** top table
4. Immobilize flange **23** by means of the flange wrench as delivered together with the equipment.
5. Loosen hexagon head screw **22** clockwise with the tubular key as delivered together with the equipment.
6. Tighten button **30** to unblock the movable guard **5**.
7. Clear guard **5** by pulling it upwards.
8. Hold the disc with one hand
9. Remove the flange and the hexagon head screw.
10. Remove the disk to be changed.

### Changing the cutting disk

1. Carefully clean sawdust and debris from the supports, flanges and the insides of the guards.
2. Place the new cutting disk in such a manner that the direction of the arrow of the front side of the casing **1** coincides with the arrow engraved in the disk and with the direction of the disk teeth as such.
3. Place the flange and the hexagon head screw **22**.
4. Block flange **23** with the flange wrench as delivered together with the equipment.
5. Tighten screw **22** counter clockwise by means of the tubular key as delivered together with the equipment.
6. Place guard **5** in its original protective position.
7. Revise the operation by carrying out a cutting operation with no load.

## 10. Fixing for operation

Whenever possible, the workpiece must be fixed in such a manner that the hand does not intervene. During the cut, keep the workpiece fixed to the support. ALL MACHINES ARE PREPARED FOR MOUNTING CLAMPS ALLOWING FASTENING THE PROFILE IN A SAFE MANNER.

To avoid deformations of the workpieces during fixing thereof, the use of wooden profiles being easily applicable to the movable jaws of the clamps is advised. Clamps can be easily extracted and leave the working surface totally clear.

For cutting long workpieces under safe conditions it is essential to hold them with additional supports.

## 11.Limits regarding the workpiece size

Limits for all models as included in the present manual

### SC250W:

Kind of cut	Limit of the workpiece size in mm
90°	140x75
45°	90x75
45° Inclined	130 x 52
45°-45°Composed	70 x 50
Upper table	0-40

### SC2500W:

Kind of cut	Limit of the workpiece size in mm
90°	135x75 / 60x95
45° right	90x75 / 35x100
45° left	90x75 / 35x100
45° Inclined	135x45 / 55x65
45°-45°Composed	43x65 / 85x55
0° linear	60x95
45° linear	55x65
Tube	ø 75
Upper table	0-40

### SC2600W:

Kind of cut	Limit of the workpiece size in mm
90°	55x125
45° Inclined	45x125
45°-45°Composed	45x80
45° linear	55x80
Upper table	0-42

## 12.General instructions for use

### Warning!

1. Do NOT use the machine if it is in a bad condition or lacks parts including the prescribed upper guards (the illustrations of the present manual may be used as an orientative guide). Unplug it, remove it from the working area and immediately send it to an authorized technical service.

2. Know and comply with all safety measures before you start the machine.
3. Obligatory used of aspiration particle system when cutting the wood.

## Starting and stopping the machine

### IMAGES



### Information

1. The machine is provided with a locking button 3 for starting allowing the motor to run without needing to push switch 2 permanently.
2. The equipment is provided with a safety module protecting it against unexpected starts. If, whilst the machine is running, the supply of electrical power should cease, the machine will not start after reestablishment thereof. To release the protection push the starting button 2 twice.
3. All models are single speed.

### Warnings!

1. Avoid locking whenever possible (button 3).
2. Never leave running machine unattended.
3. Never start the machine with locked disk and, before starting a cut, always wait until the cutting disk has reached its maximum speed.
4. Before stopping the machine the disk must be clear and be rotating freely.

### Starting with the manual switch

1. Push switch 2 to actuate the motor.

### Stopping the machine when actuated with the manual switch

1. Stop pushing switch 2.

### Starting with locking

1. Push switch 2.
2. Push locking button 3 whilst keeping switch 2 pushed.
3. Release switch 2.

### Stopping the machine when actuated with locking

Push switch **2** briefly.

---

### Use of the lower cutting table

---

#### Warning!

1. At those models that are provided with an upper cutting table, the risk of accidents due to a contact with the cutting disk appearing at the upper table. For your own safety, carry out the following preparation before working with the lower table.
2. It is mandatory to carry out any settings with the cable unplugged.

---

### Safety setting of the upper cutting table for cutting operations with the lower table

---

#### IMAGES



#### Information

This chapter is applicable to models provided with an upper table: SC250WPRO, SC265W, SC291W, SC2500W, SC2600W and SLL265W.

1. Loosen the screw of the shaft and release lock (**38**) of the guard of the upper cutting table **25**.
2. Loosen the 3 wing nuts **24** that regulate the height of the upper table.
3. Raise upper table **25** smoothly pulling upwards until abutment.
4. Firmly tighten the 3 wing nuts **24**.
5. Firmly tighten the screws of the guard of the upper cutting table **25**.

---

### Cutting operation with the lower cutting table

---

#### Warning!

1. Respect the limits regarding the size and material of the workpiece.
2. Use clamps to fasten the workpiece whenever possible.
3. Never lock the motor power switch when working with the lower cutting table.

The present electrical machine is capable of carrying out the following kinds of cuts on the lower table:

1. Inclined horizontal cut with a range of 0° to +- 45°.
2. Inclined vertical cut with a range of 0° to 45°.
3. Combinations of the horizontal and vertical ranges (for example as an abrasive cutoff machine with straight cuts horizontally at 0° and vertically at 0°).

---

### Setting for inclined horizontal cutting on the lower table

---

#### IMAGES



For carrying out inclined cuts horizontally, the machine head can turn horizontally up to 90°. To facilitate work, the lower cutting table is provided with 4 pre-set positions at +- 22° 30' and at +- 45° that may be selected by means of conical drill holes in the lower cutting table **6** and the automatic locking bolt **14**.

1. Loosen the two buttons **8** for horizontal locking.
2. Raise and keep raised the anchor bolt **14** for pre set horizontal lockings.
3. Move the assembly cutting head / lower cutting table **6** to the chosen angle by means of the scale **7** that is graduated in degrees and indicator **9**.
4. Tighten buttons **8** for horizontal locking.
5. Release anchor bolt **14**.

---

### Setting for vertical inclined cutting on the lower table

---

#### IMAGES



For carrying out inclined cuts vertically, there are two abutment inclinations which are calibrated and pre-set at 0° and 45°. Use a goniometer for adjusting to intermediate angles.

1. Loosen lever **15** for vertical locking.
2. Select the cutting angle.
3. Tighten the lever **15** for vertical locking.

---

### Setting the cutting stopper on the lower table

---

#### IMAGES



1. Loosen screw **39**.
2. Insert profile **41** into insertion cavity **44**.
3. Push profile **41** into **40** until abutment.
4. Tighten screw **39**.
5. Loosen adjusting wing nut **43**.
6. Adjust cutting length by moving stopper **42**.
7. Tighten adjusting wing nut **43**.

---

### Carrying out the cutting operation on the lower table

---

#### IMAGES



1. Prepare workpiece by fastening it in a completely safe manner.
2. Start the electrical machine by pushing switch **2**.
3. Wait for some seconds until the cutting disk reaches its maximum speed.
4. Slowly lower the operating head by a continuous manner and without jerks, using hand grip **4**.



5. Exert pressure in the blade's direction of advance with an intensity being suitable for the material to be cut.
6. Once the cutting operation has been completed, raise operating head again. Stop the machine by pushing switch **2**.

---

### Use as circular saw by means of the upper cutting table

---

#### Information:

This chapter is applicable to models provided with an upper table: SC250WPRO, SC265W, SC291W, SLL265W, SC2500W and SC2600W.

#### Warning!

Before carrying out any operation on the upper cutting table it is mandatory to prepare the machine suitably. For this purpose, the stationary safety guard is to be installed on the lower table.

---

### Installing the stationary safety guard on the lower cutting table

---

#### IMAGES



1. Begin with the head raised and the cable unplugged.
2. Loosen frontal wing nut **24**.
3. Insert the guide of safety guard **34** onto the screw of wing nut **24**.
4. Apply guard **34** at its location according to the figure.
5. Smoothly lower the head and block it by means of button **31**.
6. Push guard **34** downwards ensuring that the guard abuts against the lower cutting table.
7. Firmly tighten wing nut **24**.
8. Check that the blade rotates freely.
9. Finally, briefly start the machine without load and ensure that the disk does not friction.
10. Disconnect the electrical power jack again.

---

### Setting the upper table

---

#### Setting the height of the upper cutting table

#### IMAGES



#### Information:

The height of the upper cutting table can be adjusted from 0 to 42mm.

#### Warning!

The height of the upper cutting table in respect of

the cutting disk must be such that the disk protrudes from the workpiece only by a height equal to that of the saw tooth. See image **W**.

1. If tightened, slightly loosen the screw of the shaft of the guard of table **25** such that the guard ascends freely.
2. If tightened, loosen lock **38** of the guard of table **25** such that the guard ascends freely.
3. Loosen the wing nuts **24** that regulate the height of the upper table.
4. Adjust the height of the table by smoothly pulling it upwards.
5. Firmly tighten the wing nuts **24**.

---

### Setting the cutting width on the upper table by means of the guide

---

#### IMAGES



1. Release movement of the parallel guide **27** by loosening wing nut **28**.
2. Adjust the cutting width by moving the guide **27** on the graduated scale **45**.
3. Fasten guide **27** by firmly tightening the wing nut **28**.

---

### Using the goniometer

---

#### Information!

#### IMAGES



The upper working table is set for the optional use of a goniometer that is adjustable between 0° and 45°. The regular use of the goniometer is for cutting slanted cuts, but there is the possibility to use the goniometer as a depth control stop for adjustable cutting. Mount the goniometer at the right side of the upper cutting table for this purpose.

There is a model-specific goniometer for upper aluminum tables (SC250W, SC265W, SC291W, SC2500W and SLL265W) and another for upper steel-plate tables (SC250WPRO).

1. Loosen the lower wing nut for coupling to the upper cutting table.
2. Insert the goniometer into the front slot of the upper cutting table.
3. Adjust the position of the goniometer in accordance with the work to be carried out.
4. Tighten the wing nut for coupling the goniometer to the upper cutting table.
5. Loosen the upper wing nut for adjusting the angle of the goniometer.
6. Adjust the angle of the goniometer in accordance with the work to be carried out.
7. Tighten the upper wing nut for adjusting the angle of the goniometer.
8. Loosen the upper stop-extension wing nuts of the goniometer.

9. Adjust the extension of the stop of the goniometer in accordance with the work to be carried out.
10. Tighten the upper stop-extension wing nuts of the goniometer.

---

### Carrying out the working operation on the upper cutting table

---

1. Carry out the starting operation with locking as explained in 12.
2. For longitudinal cuts use the parallel guide to support the workpiece.
3. Approach the workpiece to the cutting disk applying maximum caution keeping your hands distanced from the cutting path.
4. Push the workpiece with an intensity that is suitable for the characteristics of the material.
5. Carry out the stopping operation with locking as explained in 12.

#### Information!

Only for models SC250W, SC265W, SC291W, SC2500W, SC2600W and SLL265W. Once it has been placed at the left of the saw blade, parallel guide 27 allows to cut small cuttings at 45°

## 13. Precautions and protective garment

This electrical tool may only be handled by adult personnel who have received suitable training and instructions, complying with laws as established to this respect and what has been set forth as a matter of prevention for the working place.

In addition, the operator must have understood and assimilated, and fully comply with the present manual.

This machine requires the use of the following individual protective equipments:

1. Protective helmet
2. Integral face-protecting equipment (eyes and face) against impacts
3. Ear protectors
4. Dust mask
5. Protective gloves against mechanical aggression
6. Boots with toe caps and insoles
7. Working garment
8. Tool bag
9. Safety belt (occasional)

## 14. Special safety precautions

---

### Safety Precautions

---

- Do not use saw blades that are damaged or deformed.
- Do not use the saw without guards in position, especially after a mode change, and keep guards in good working properly maintained.

- Replace the block of the table when worn.
- Only use blades recommended by the manufacturer saw, with a warning that the keel should not be thicker than the width of the groove of the cut made by the saw blade and not thinner than the body of the blade; Specific saw blades for cutting wood must comply with EN 847-1.
- Do not use saw blades made of high speed steel.
- Dressing appropriate personal protective equipment when necessary, which may include:
  - Hearing protection to reduce the risk of induced hearing loss.
  - Eye protection.
  - Respiratory protection to reduce the risk of inhalation of harmful dust.
  - Wear gloves when handling saw blades and rough materials (leaves should be on a stand whenever practicable).
- Connect the saw to a dust collection system when sawing wood.
- Always store the push stick in place when not in use

---

### Description of risks specifically related to the machine

---

Any of the following prior risk conditions must have existed for the risks to become real:

1. The operator has not been suitably trained.
2. The mitre saw has not been installed suitably.
3. The mitre saw has not been maintained correctly.
4. The mitre saw has been disassembled and then been assembled incorrectly.
5. The mitre saw has been disassembled and assembled with parts lacking.
6. Operator does not use the protection as indicated.
7. Operator grasps the workpiece with his/her hand.
8. Operator exposes his/her hands, body or garment to the cutting path.

The two main classes of risks entailed by the use of this machine are contacts with the cutting disk and projections of particles or cut pieces.

---

### 1. Contact with the cutting disk

---

**Case of use 1.1:** During the development of the cutting operation

**Description of an accident of type 1.1.1:** The appearance of a nod in the wood leading to a change in the resistance to penetration causes an abrupt jerk in the workpiece and thus the possibility that the operators hand is suddenly displaced towards the disk and contacts the same if it remains accessible.

**Description of an accident of type 1.1.2:** This occurs during headpiece cutting operations at workpieces having a very short length being held manually. When the disk penetrates into the workpiece, the latter may fall into the disk's penetration slot of the cutting table and thus drag the hand that holds the workpiece, making it enter into contact with the disk if it remains accessible.

**Case of use 1.2:** Fortuitous contact with the disk when turning without load in the resting position

**Description of an accident of type 1.2.1:** It occurs when working with a machine that has been manipulated or lacking guards. Under these conditions the actuating element remains locked such that the operator maintains the disk rotating without load in the resting position and with the disk being accessible. At the same time the operator's hand enters into contact with the cutting disk whilst carrying out operations in areas in the vicinity of the disk (e.g. removing the cut workpiece, placing a new workpiece on the table, etc.)

**Case of use 1.3:** Abrupt fall if the disk due to breakage of the fastening spring in the resting position

**Description of an accident of type 1.3.1:** There occurs the drop of the counterweight of the movable head sustaining the cutting disk due to breakage of one or both of the counterweight springs or of the anchoring thereof. At the same time the disk remains rotating without load. At the same time the operator has his/her hands under the cutting path. Under these conditions the disk catches up with the operator's hands that at that moment are carrying out operations in that area.

---

## 2. Projection of the cut workpiece

---

Case of use 2.1: Abrupt fall if the disk due to breakage of the fastening spring in the resting position

Description of an accident of type 2.1: This risk appears when operating on short workpieces with fixed stoppers. After completing the cut and raising the disk, the remnant wedged between the stopper and the disk may be dragged thereby and projected violently, and in the worst case even lead to a breakage of the disk.

# 15. Measure for preventing machine-specific risks

---

## 1. Preventing contacts with the cutting disk

---

### 1.1 Prevention during the development of the cutting operation

1. The operator must mandatorily be sufficiently trained and instructed, and know the present manual in such a manner that he/she is able to know if a machine or his/her working environment are suspicious of not providing a perfect service. Do not use the machine under these circumstances!
2. Revise any lack of guards or any other component of the machine. Never use a machine that is not complete, not in a perfect condition and not correctly installed. If the machine has been manipulated, lacks pieces or is in a bad condition, disconnect it, remove it from the working area, do not use it and send it to the technical service.
3. Never put your hands or any other part of the body nor garment upon or below the cutting area of the

disk or within the cutting path of the disk.

4. Fastening the workpiece to be cut shall not be carried out manually but with the assistance of pushers, wedgers and clamps warranting a firm fastening of the workpiece to be cut under any circumstances (appearance of nuds, etc.). By putting this preventive measure into practice the risk of contact with the disks during the development of the operation is practically excluded as it allows hands to remain distanced from the hazardous area.
5. Always disconnect the machine when leaving it alone.
6. The presence of one or more assistants will be required for cutting workpieces being longer than 1.5 m.

### 1.2 Preventing fortuitous contacts with the disk rotating without load in the resting position

Independently from that the disk, when resting, stays protected by the safety guards as installed, it is categorically advised against using the locking switch so as to guarantee that disk does not rotate without load in the resting position thereof.

### 1.3 Preventing abrupt falls of the disk due to breakage of the spring

1. By means of a regular maintenance the machine will always be in a perfect condition.
2. Check the area and the machine on each working day and routinely test all movements visually with the machine disconnected.
3. Check springs **32** and the bearings thereof on each working, and have them checked periodically by qualified personnel.
4. Make sure that the head perfectly ascends to its upper position by the sole action of springs **32**.
5. Check the upper locking system on each working day by raising the head up to abutment and checking locking and unlocking by means of button **29**, and have this periodically checked by qualified personnel.
6. Never expose your hands or any other part of your body to the cutting path.
7. Never allow the head that holds the disk to remain in an undetermined position unless the operator is mandatorily grasping the control grip **4**.
8. For any break between cuttings, however short it may be, always use the automatic lock of the head in the upper position by raising the head to the upper stopper.
9. Each time that the machine remains at rest, leave it in the lower resting position by placing the head at 90° vertical and 0° horizontal, protecting by means of the stationary guard **34** and finally locking it by lowering the head and pushing button **30**.

---

## 2. Preventing projections of the cut workpiece

---

So as to carry out the cutting of workpieces using a stopper, this latter must be foldable or movable. Once the operator has selected the cutting range and firmly fixed the workpiece to the table, he/she

will remove the stopper so as to prevent the workpiece as cut from wedging between the stopper and the disk.

## 16. Dust extraction

### IMAGE **C**

All models are prepared for mounting equipment (not included) for the aspiration of particles generated during the cutting operation. The extraction equipment shall be coupled to the particle outlet nozzle **20**.

### Mechanical protective equipment

### IMAGES **V X**

1. General protective casing **1**.
2. Tilttable protective hood **5**.
3. Lower stationary guard **34**.
4. Movable guard of the upper table **26**.

### Electrical protective equipment

1. Class II electrical insulation.
2. Protective module for electrical grid failures so as to avoid fortuitous starts of a machine after recovery after a cut off of the electrical supply.

## 17. General safety instructions

**WARNING!** When using electrical tools, the essential safety precautions should always be taken to reduce the risks of fire, electrical shock and personal damages, including the following. Read these instructions with attention before using this product, and store them.

## 18. Regular cleaning, maintenance and greasing

**WARNING!** .Desenchufar the plug before performing any adjustment or maintenance comeback.

### Cleaning

Clean the machine starting with a brush or with a flat brush so as to remove sawdust and with a soft cloth. If compressed air is available, complete cleaning by blowing with the compressed air pistol.

### Maintenance

After each 2,000 hours of use or each two years the electrical tool must be sent to the official technical service for maintenance and complete revision.

Before each use, check nuts and joints to detect any vibration issues and use. If there are gaps take the machine to service.

Except squeeze and brush change, the machine does not require any special maintenance by the user. Keep the machine clean and use it correctly. Regularly have the correctness of the adjustments checked by a sufficiently trained user. In the case of any failure, contact our technical service.

### Changing brushes

#### Warning!

Always use the brushes as supplied by the official technical service.

1. Remove screw **48**.
2. Remove lid **47**.
3. Remove screw **50**.
4. Move pressing spring **51** to the left.
5. Extract used **52** brush from the brush holder **49**.
6. Insert new brush into the brush holder **49**.
7. Place pressing spring **51** over the brush.
8. After applying the brush connector tighten screw **50**.
9. Position lid **47**.
10. Tighten screw **48**.

### Greasing

This machine does not require any specific greasing by the user. Specific greasing of the electrical tool will be carried out on the occasion of the regular maintenance revisions at the official technical service.

## 19. Repair service of the manufacturer or commercial agent:

Stayer Ibérica S.A.  
Área Empresarial de Andalucía - Sector 1.  
C/ Sierra de Cazorla, 7. Postal code: 28320 Pinto (Madrid) Spain.

## 20. List of parts that may be replaced by the user

### IMAGES **Y Z**

1. Cutting disk **21**.
2. Lower stationary guard **34**.
3. Movable guard **26**.
4. Brushes **52**.
5. Guides for adjusting the cutting depth at the lower table **41**.
6. Guides for adjusting the cutting depth at the lower table **27**.



## 21. Special tools as possibly required

Tools as required are standard or included with the accessories of the machine.

## 22. Safe operation

1. **Keep working area clean.** Unorderly working areas and benches are susceptible of causing damages.
2. **Take into account the surroundings of the working area.** Do not expose tools to rain. Do not use tools at humid or wet locations. Keep working area well illuminated. Do not use tools in the presence of inflammable liquids or gases.
3. **Protect against electrical shocks.** Avoid contacts of the body with earthed or chassis-earthed surfaces (e.g. pipes, radiators, heaters, refrigerators, etc.).
4. **Keep other persons away.** Do not allow that other persons, especially children, who are not linked to the work, touch the tool or extensible cables, and keep them away from the working area.
5. **Store tools that are not being used.** When not in use, tools should be stored at a dry and closed location out of the reach of children. Do not place anything on top of the machine, or store the machine start backwards.
6. **Do not force the tool.** The tool operated better and safer at the assigned characteristic for which it has been designed.
7. **Choose the right tool.** Do not force a small tool to carry out the work that corresponds to a heavy tool. Do not use tools for purposes for which they have not been designed; for instance, do not use circular saws for cutting the trunks of trees or the branches thereof.
8. **Dress suitably.** Do not use loose-fitting garment or jewellery articles that may get caught by moving parts. The use of nonslip footwear is recommended for working at outside locations. For long hair use protective caps.
9. **Use safety equipment.** Use protective goggles. Use face protector or mask to avoid dust if the cutting operations may generate it.
10. **Connect the dust-extraction equipment.** Should devices for the connection thereof to dust extraction and collection equipments be provided, make sure that they are in fact connected and adequately used.
11. **Do not mistreat the cables.** Never pull the cable to disconnect it from the socket. Keep the cable away from heat, oil and cutting edges.
12. **Secure operations.** When possible, use fastening clasps or clamps for workbenches for fastening the workpiece. This is safer than using your hands.
13. **Do not excessively extend our radius of operation.** Always keep a firm stand on the ground and preserve your equilibrium.
14. **Service tools carefully.** Keep cutting tools sharpened and clean for a better and safer operation thereof. Follow the instructions for greasing and the changing of accessories. Periodically check extensible cables and replace them if they are damaged. Keep grips dry, clean and free of grease and oil.

15. **Disconnect the tools.** Disconnect tools from the grid supply when not in use, before repairing and when changing accessories such as saw blades, drilling bits and blades.

16. **Remove setting keys and adjustable spanners.** Make it your custom to check that setting keys and adjustable spanners are removed from the tool before it is operated.

17. **Avoid unintentional starting.** Make sure that the switch is in the "open" position when plugging the machine into the socket.

18. **Use extensible cables for outside use.** When using the tool at an outside location, only use extensible cables for outside use that are marked for this purpose.

19. **Be alert.** Look at what you are doing, use common sense and do not work with the machine when you are tired.

20. **Check damaged parts.** Before using a tool again, it should be carefully checked so as to determine that it will operate suitably and be apt for the operation which has been assigned to it. Examine alignment, fixing and tightening of mobile and fixed parts, breakage of parts, mounting, and other conditions that may affect its operation. A damaged guard or other part should be suitably repaired or replaced by an authorized technical service unless anything else is stated in the instructions manual. Have faulty switches replaced by an authorized technical service. Do not use the tool if the switch does not switch on or switch off.

21. **Warning:** The use of any accessories or supplements other than one recommended in this instructions manual may generate personal damages.

22. **Have the tool repaired by qualified personnel.** This electrical tool complies with the appropriate safety requirements. Repairs should be carried out by qualified personnel only using original spareparts; otherwise, a considerable risk could be generated for the user.

## 23. Technical specifications

Measure to be kept by saw blades (En847):

Diameter of the saw blade: 254 mm, Thickness of the base disk: 1.8 – 2.8 mm, Hole diameter: 30 mm

Information on noise and vibration

The typical noise pressure level of the apparatus as determined with an A-filter is: see table.

Wear ear protection!

The typical vibration transmitted to the hand / arm is lower than 2.5 m/s<sup>2</sup>.

## 24. Warrantee

### Warrantee card

You will find the warrantee card among the documents belonging to the tool. You must fill in the warrantee card completely and attach a copy of the purchase ticket or invoice thereto, and give it to your distributor against the corresponding acknowledgement of receipt.

**Observation!** Should this card be lacking, immediately request your distributor to furnish it.

**Terms of warrantee**

As professional equipment, the warrantee period is set to one year as from the date of purchase.

The warrantee will immediately cease to exist when the client's service of the central offices does not have the warrantee card within a one-month term as of the date of purchase.

The warrantee will equally cease to exist when the machine has been used in an inappropriate manner or making use of accessories being unsuitable for the uses as foreseen by the manufacturer.

The warrantee is limited solely to manufacturing or mechanization failures, and it ceases to exist when parts thereof have been disassembled, manipulated or repaired out of the manufacturing plant.

STAYER obliges itself to repair or replace the product or the parts thereof that may be faulty, free of charge only after a check and at the exclusive criterion of its technicians.

It is considered that all costs for transportation and disassembling will be borne by the purchaser.

So as to facilitate the technicians' work, please attach a description of the failures that the client has noticed at the tool during the use thereof.

**25. Declaration of Conformity****EU DECLARATION OF CONFORMITY**

The undersigned: STAYER IBÉRICAS.A.

With address at:

Calle Sierra de Cazorla, 7  
Área Empresarial Andalucía  
Sector 1 - 28320 PINTO (MADRID)  
Tel.: 902 91 86 81/ Fax: 91 691 91 72

**CERTIFIES,**

That the machine:

Type: COMBINED MITRE SAWING AND BENCH SAWING MACHINES.

Model: SC250W PRO, SC250W, SC265W, SC291W, SC2500W, SC2600W, SLL265W

Are in conformity with the provisions of Directive 2006/42/EC, 2014/30/EU:

As well as with the following regulations:  
EN 60745-1, EN 61029-1, EN 61029-2-11,  
EN 55014-1, EN 55014-2, EN 61000-3-2,  
EN 61000-3-3

It has received a Type Certificate with the number

**43/3M/02/000024** (SC250WPRO, SC250W, SC265W, SLL265W, SC291W, SC2500W)

Issued by the notified body:

0056 ECA, ENTIDAD COLABORADORA DE LA ADMINISTRACIÓN S.A.U.

Av. Roma, 21 / 43005 TARRAGONA

Signed: Ramiro de la Fuente  
Director General



January 1, 2017

 R&S CE

**TECHNICAL DATA**

Model	Absorbed power	rpm without load	Weight kg	Protection class	Noise K=3dB	
					L <sub>PA</sub>	L <sub>WA</sub>
SC250WPRO	1500	3800	14.5	II	89	101
SC265W	1500	3800	15.5	II	89	101
SC291W	1600	3000	15.5	I	86	98
SC2500W	1800	3800	15.5	II	86	101
SC2600W	1900	4700	17	II	92	103
SLL265W	1500	3800	16.2	II	89	101
SC250W	1800	4200	15.5	II	92	103

The values given are valid for nominal voltages [U] 230/240 V ~ 50/60 Hz - 110/120 V ~ 60 Hz. For lower voltage and models for specific countries, these values can vary. Please observe the article number on the type plate of your machine. The trade names of the individual machines may vary.



**STAYER**

Área Empresarial Andalucía - Sector I  
Calle Sierra de Cazorla nº7  
C.P: 28320 Pinto (Madrid) SPAIN  
Email: [info@grupostayer.com](mailto:info@grupostayer.com)



[www.grupostayer.com](http://www.grupostayer.com)