



STAYER

- ES** Manual de instrucciones
- IT** Istruzioni d'uso
- GB** Operating instructions
- FR** Instructions d'emploi
- P** Manual de instruções

MULTITOO L PRO 300



STAYER

Área Empresarial Andalucía - Sector I
Calle Sierra de Cazorla n°7
C.P: 28320 Pinto (Madrid) SPAIN
Email: sales@grupostayer.com
Email: info@grupostayer.com

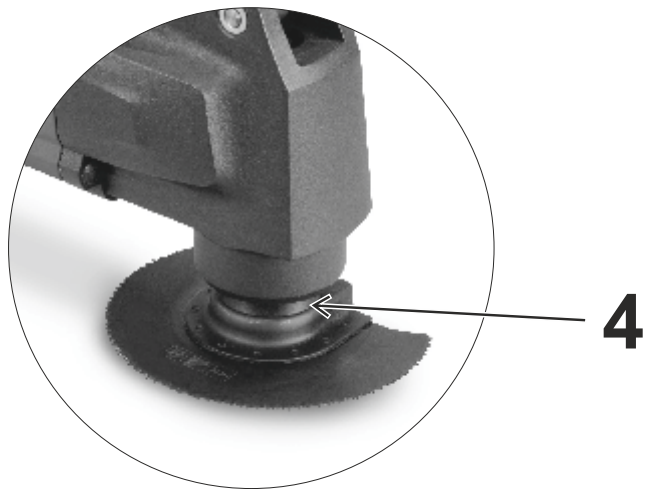

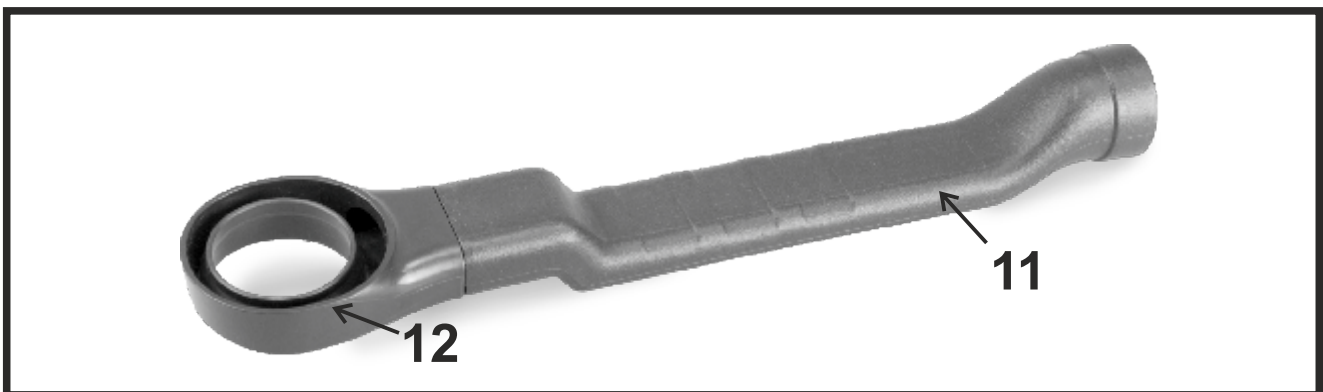
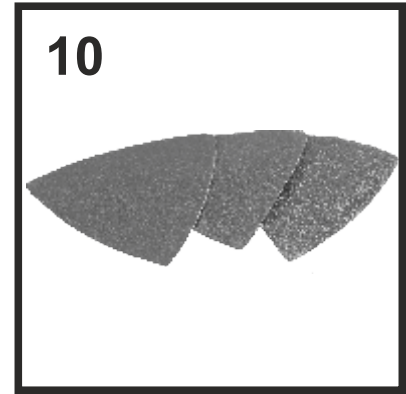
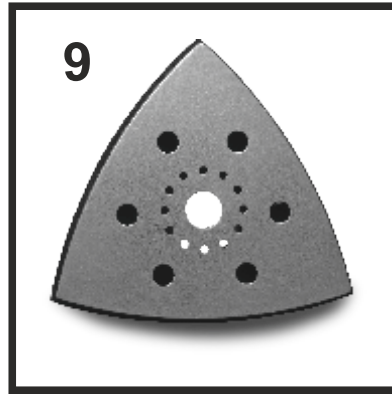
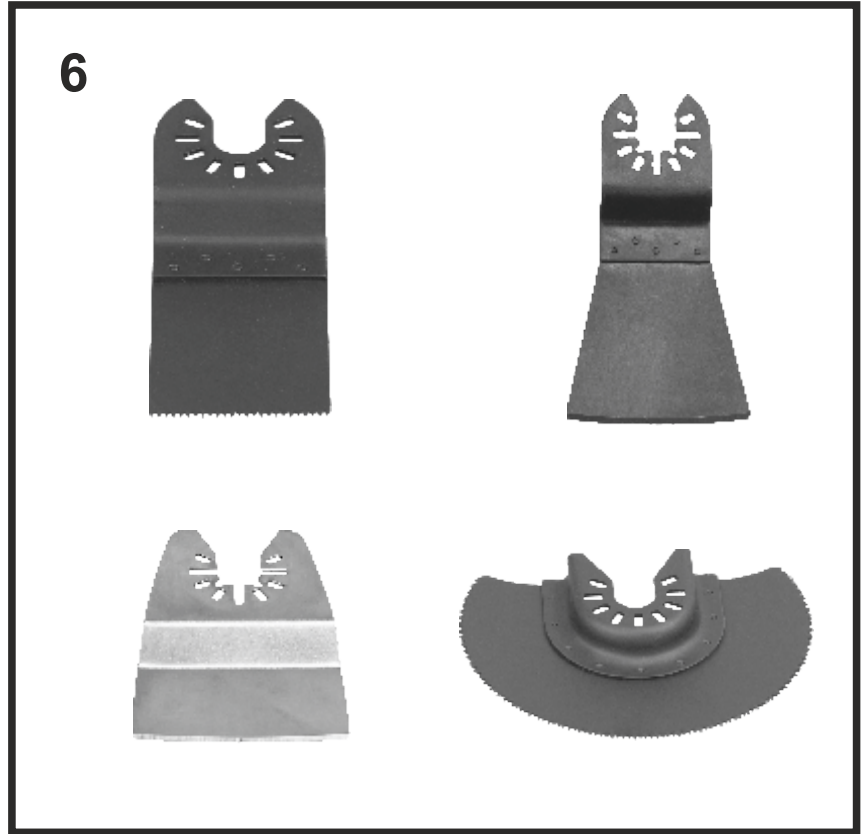

1. Safety Notes

Safety Warnings for Precision Saw

- **Hold power tool by insulated gripping surfaces, when performing an operation where the cutting accessory may contact hidden wiring.** Cutting accessory contacting a “live” wire may make exposed metal parts of the power tool “live” and could give the operator an electric shock.
- **Use the machine only for dry sanding.** Penetration of water into the machine increases the risk of an electric shock.
- **Keep hands away from the sawing range. Do not reach under the workpiece.** Contact with the saw blade can lead to injuries.
- **Use suitable detectors to determine if utility lines are hidden in the work area or call the local utility company for assistance.** Contact with electric lines can lead to fire and electric shock. Damaging a gas line can lead to explosion. Penetrating a water line causes property damage or may cause an electric shock.
- **When working with the machine, always hold it firmly with both hands and provide for a secure stance.** The power tool is guided more secure with both hands.
- **Secure the workpiece.** A workpiece clamped with clamping devices or in a vice is held more secure than by hand.
- **Keep your workplace clean.** Blends of materials are particularly dangerous. Dust from light alloys can burn or explode.
- **Never use the machine with a damaged cable. Do not touch the damaged cable and pull the mains plug when the cable is damaged while working.** Damaged cables increase the risk of an electric shock.
- **Wear protective gloves when changing application tools/accessories.** Application tools/accessories become hot after prolonged usage.
- **Do not scrape wetted materials (e. g. wallpaper) or on moist surfaces.** Penetration of water into the machine increases the risk of an electric shock.
- **Do not treat the surface to be worked with solvent-containing fluids.** Materials being warmed up by the scraping can cause toxic vapours to develop.
- **Exercise extreme caution when handling the scraper.** The accessory is very sharp; danger of injury.
- **Products sold in GB only:** Your product is fitted with an BS 1363/A approved electric plug with internal fuse (ASTA approved to BS 1362).
If the plug is not suitable for your socket outlets, it should be cut off and an appropriate plug fitted in its place by an authorised customer service agent. The replacement plug should have the same fuse rating as the original plug.
The severed plug must be disposed of to avoid a possible shock hazard and should never be inserted into a mains socket elsewhere.
- **Products sold in AUS and NZ only:** Use a residual current device (RCD) with a rated residual current of 30 mA or less.

2. Functional Description



Read all safety warnings and all instructions. Failure to follow the warnings and instructions may result in electric shock, fire and/or serious injury.

While reading the operating instructions, unfold the graphics page for the machine and leave it open.

Intended Use

The machine is intended for sawing and cutting wooden materials, plastic, gypsum, non-ferrous metals and fastening elements (e.g., unhardened nails, staples). It is also suitable for working soft wall tiles, as well as for dry sanding and scraping of small surfaces. It is especially suitable for working close to edges and for flush cutting. Operate the power tool exclusively with **Stayer** accessories.

Product Features

The numbering of the product features refers to the illustration of the machine on the graphics page.

- 1.- On/Off switch
- 2.- Thumbwheel for orbit frequency preselection
- 3.- Venting slots
- 4.- Tool holder
- 5.- Handle (insulated gripping surface)
- 6.- Cutting or sanding tool.
- 7.- Clamping bolt with spring washer
- 8.- Allen key
- 9.- Sanding plate
- 10.- Sanding sheet
- 11.- Dust extraction device .
- 12.- suction nozzle.
- 13.- Lever useful change

Technical Data

MULTI TOOL PRO 300

<i>Rated power input</i>	W	300
<i>No-load speed</i>	min ⁻¹	15.000 - 23.000
<i>Orbit</i>	mm	3.2
<i>Weight</i>	kg	1.5

These data are valid for nominal voltages of [U] 230/240 V ~ 50/60 Hz – 110/120 V ~ 60 Hz. These values may change of the voltage was lower and in the specific embodiments for certain countries. Pay attention to the Article No. on the plate of specifications of your apparatus as the commercial denominations of some apparatus may vary.

Noise/Vibration Information

Measured sound values determined according to EN 60745.

Typically the A-weighted noise levels of the product are:
Sound pressure level 81 dB(A);
Sound power level 92 dB(A).
Uncertainty K=3 dB.

Wear hearing protection!

Vibration total values (triax vector sum) determined according to EN 60745:

Sanding: Vibration emission value

$a_n=2 \text{ m/s}^2$, uncertainty $K=1.4 \text{ m/s}^2$

Cutting with plunge cut saw blade: Vibration emission value

$a_n=10 \text{ m/s}^2$, uncertainty $K=1.5 \text{ m/s}^2$

Cutting with segmental saw blade: Vibration emission value

$a_n=6.5 \text{ m/s}^2$, uncertainty $K=1.5 \text{ m/s}^2$

Scraping: Vibration emission value

$a_n=4.5 \text{ m/s}^2$, uncertainty $K=1.5 \text{ m/s}^2$.

The vibration emission level given in this information sheet has been measured in accordance with a standardised test given in EN 60745 and may be used to compare one tool with another. It may be used for a preliminary assessment of exposure.

The declared vibration emission level represents the main applications of the tool. However if the tool is used for different applications, with different accessories or poorly maintained, the vibration emission may differ. This may significantly increase the exposure level over the total working period.

An estimation of the level of exposure to vibration should also take into account the times when the tool is switched off or when it is running but not actually doing the job. This may significantly reduce the exposure level over the total working period.







Identify additional safety measures to protect the operator from the effects of vibration such as: maintain the tool and the accessories, keep the hands warm, organisation of work patterns.

3. Assembly

Changing the Tool

- **Before any work on the machine itself, pull the mains plug.**
- **Wear protective gloves when changing application tools/accessories.** Contact with the application tool/accessory can lead to injuries.

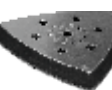
Selecting the Application Tool/Accessory

Accessory	Material
 HSS wood segment saw blade	Wooden materials, plastic
 BIM segment saw blade	Wooden materials, plastic.
 HSS plunge cut saw blades, wood	Wooden materials, plastic, gypsum and other soft materials
 BIM plunge cut saw blades, metal	Metal (e.g. unhardened nails, screws, smaller profiles), non-ferrous metals
 BIM plunge cut saw blade, wood and metal	Wood, metal, non-ferrous metals
 Base plate for sanding, series Delta 93 mm.	Depends on sanding sheet

Mounting/Replacing the Application Tool/Accessory

180 Turn the lever 7 to extract useful and change it. Re turn around to fix the tool.

- **Check the tight seating of the application tool/accessory.** Incorrect or not securely fastened application tools/accessories can come loose during operation and pose a hazard.

Mounting/Replacing a Sanding Sheet on the Sanding Plate

The sanding plate 9 is fitted with Velcro backing for quick and easy fastening of sanding sheets with Velcro adhesion.

Before attaching the sanding sheet 10, free the Velcro backing of the sanding plate 9 from any debris by tapping against it in order to enable optimum adhesion.

Position the sanding sheet 10 flush alongside one edge of the sanding plate 9, then lay the sanding sheet onto the sanding plate and press firmly.

To ensure optimum dust extraction, pay attention that the punched holes in the sanding sheet match with the holes in the sanding plate.

To remove the sanding sheet **10**, grasp it at one of the tips and pull it off from the sanding plate **10**.

Selecting the Sanding Sheet

Depending on the material to be worked and the required rate of material removal, different sanding sheets are available:

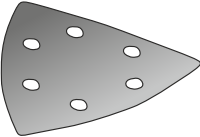
Sanding disc	Material	Application	Grain size	
 <p>Red quality</p>	- All wooden materials (e.g., hardwood, softwood, chipboard, building board) - Metal materials	For coarse-sanding, e.g. of rough, unplanned beams and boards	coarse	60
		For face sanding and planing small irregularities	medium	80
		For finish and fine sanding of wood	fine	210

Dust/Chip Extraction

- Dusts from materials such as lead-containing coatings, some wood types, minerals and metal can be harmful to one's health. Touching or breathing-in the dusts can cause allergic reactions and/or lead to respiratory infections of the user or bystanders. Certain dusts, such as oak or beech dust, are considered as carcinogenic, especially in connection with wood-treatment additives (chromate, wood preservative). Materials containing asbestos may only be worked by specialists.
 - As far as possible, use a dust extraction system suitable for the material.
 - Provide for good ventilation of the working place.
 - It is recommended to wear a P2 filterclass respirator.
 Observe the relevant regulations in your country for the materials to be worked.

Connecting the Dust Extraction (see figure A)

For sanding, always connect dust extraction.

Remove the application tool/accessory when mounting the dust extraction **11** (accessory).

If required, assemble the parts of the dust extraction **11** as shown in the figure. Position the assembled dust extraction onto the machine via the tool holder **4**.

Depending on machine version, place a vacuum hose (accessory) either directly onto the vacuum connection **12**. Connect the vacuum hose with a vacuum cleaner (accessory). An overview for the connection of various vacuum cleaners can be found on the fold-out page.

The vacuum cleaner must be suitable for the material being worked.

When vacuuming dry dust that is especially detrimental to

health or carcinogenic, use a special vacuum cleaner.

4. Operation

- **Observe correct mains voltage! The voltage of the power source must agree with the voltage specified on the nameplate of the machine. Power tools marked with 230 V can also be operated with 220 V.**

Starting Operation

Switching On and Off

To **start** the machine, push the On/Off switch **1** forward so that the "I" is indicated on the switch.

To **switch off** the machine, push the On/Off switch **1** toward the rear so that the "0" is indicated on the switch.

Preselecting the Orbital Stroke Rate

With the thumbwheel for preselection of the orbital stroke rate **2**, you can preselect the required orbital stroke rate, even during operation.

The required stroke rate depends on the material and the working conditions and can be determined through practical testing.

Working Advice

Note: Do not cover off the venting slots **3** of the machine while working, as this reduces the working life of the machine.

Operating Principle

Due to the oscillating drive the application tool/accessory swings up to 21000 times per minute for 2.8°. This allows for precise work in narrow spaces.



Work with low and uniform application pressure, otherwise, the working performance will decline and the application tool can become blocked.



While working, move the machine back and forth, so that the application tool does not heat up excessively and become blocked.

Sawing

- **Use undamaged faultless saw blades only.** Deformed, blunt saw blades or saw blades that are otherwise damaged can break.
- **When sawing light building materials, observe the statutory provisions and the recommendations of the material suppliers.**
- **Plunge cuts may only be applied to soft materials, such as wood, gypsum plaster boards, etc.!**

Before sawing with HSS saw blades in wood, particle board, building materials, etc., check these for foreign objects such as nails, screws, or similar. If required, remove foreign objects or use BIM saw blades.

Sanding

The removal rate and the sanding pattern are primarily determined by the choice of sanding sheet, the preset oscillation rate and the applied pressure.

Only flawless sanding sheets achieve good sanding capacity and extend the service life of the machine.

Pay attention to apply uniform sanding pressure; this increases the working life of the sanding sheets.

Intensifying the sanding pressure does not lead to an increase of the sanding capacity, but to increased wear of the machine and the sanding sheet.

For precise on-the-spot sanding of edges, corners and hard to reach areas, it is also possible to work only with the tip or an edge of the sanding plate.

When selectively sanding on the spot, the sanding sheet can heat up considerably. Reduce the orbital stroke rate and allow the sanding sheet to cool down regularly.

A sanding sheet that has been used for metal should not be used for other materials.

For sanding, always connect dust extraction.

Scraping

For scraping, select a high oscillation rate. Work on a soft surface (e.g. wood) at a flat angle, and apply only light pressure. Otherwise the scraper can cut into the surface.

5. Maintenance and Service

Maintenance and Cleaning

- **Before any work on the machine itself, pull the mains plug.**
- **For safe and proper working, always keep the machine and ventilation slots clean.**

Clean Riff application tools (accessory) regularly with a wire brush.

If the machine should fail despite the care taken in manufacturing and testing procedures, repair should be carried out by an after-sales service centre for **Stayer**.

After-sales Service and Customer Assistance

Our after-sales service responds to your questions concerning maintenance and repair of your product as well as spare parts.

Our customer service representatives can answer your questions concerning possible applications and adjustment of products and accessories.

Stayer Ibérica S.A.

Area Empresarial de Andalucía - Sector 1
Calle Sierra de Cazorla 7
28320 Pinto, Madrid (Spain)

Disposal

The machine, accessories and packaging should be sorted for environmental-friendly recycling.

Do not dispose of power tools into household waste!

Only for EC countries:



According the European Guideline 2002/96/EC for Waste Electrical and Electronic Equipment and its implementation into national right, power tools that are no longer usable must be collected separately and disposed of in an environmentally correct manner.

6. EC Declaration of Conformity

The undersigned:
STAYER IBERICA, S.A.

Whit address at:
Calle Sierra de Cazorla, 7
Área Empresarial Andalucía - Sector 1
28320 PINTO (MADRID)
Tel.: +34 91 691 86 30 / Fax: +34 91 691 91 72

CERTIFIES

That the machine:

Type:
MULTI TOOL

Model:
MULTI TOOL PRO 300

We declare under our sole responsibility that the product described under "Technical Data" is in conformity with the following standards or standardization documents: EN 60745 according to the provisions of the directives 2004/108/EC, 2006/42/EC.

Signed: Ramiro de la Fuente
Director General

January, 2017



CE  ROHS



STAYER

Área Empresarial Andalucía - Sector I
Calle Sierra de Cazorla nº7
C.P: 28320 Pinto (Madrid) SPAIN
Email: sales@grupostayer.com
Email: info@grupostayer.com



RoHS



www.grupostayer.com