



STAYER



es	Manual de instrucciones
it	Istruzioni d'uso
gb	Operating instructions
de	Bedienungsanleitung
fr	Instructions d'emploi
p	Manual de instruções
tr	Kullanma Kılavuzu
pl	Instrukcja obsługi

FH700
FH900C
FH901C



Área Empresarial Andalucía - Sector I
Calle Sierra de Cazorla nº7
C.P: 28320 Pinto (Madrid) SPAIN
info@grupostayer.com

www.grupostayer.com

VERSION E
ELECTRONIC REG.

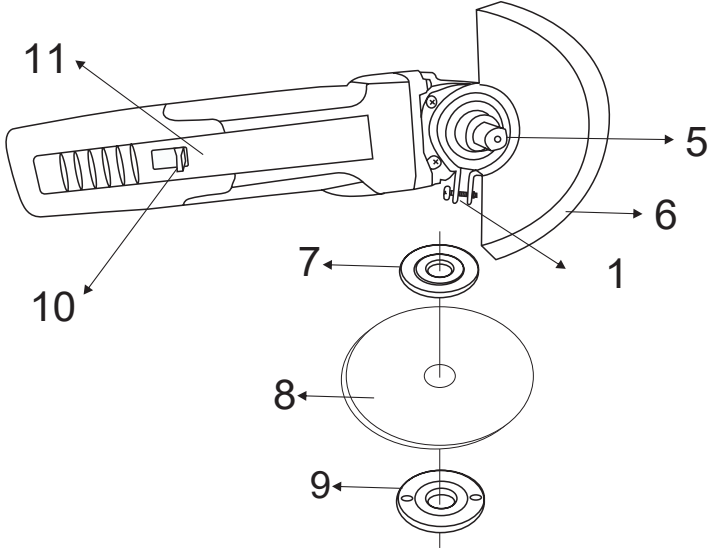
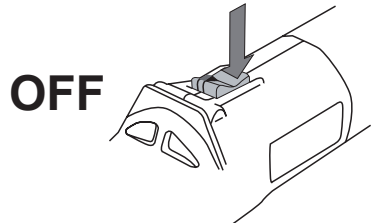
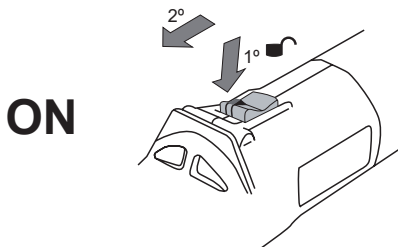
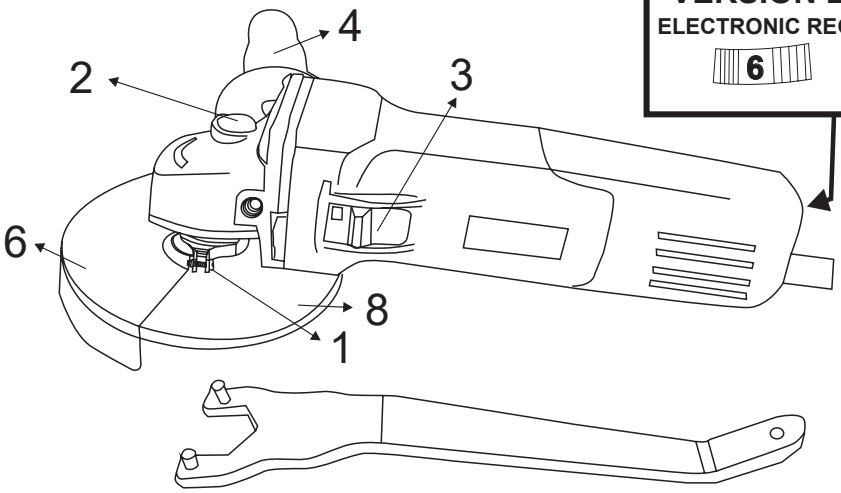



		FH700	FH900C	FH901C
	W	700	900	900
	$n_0 \text{ min}^{-1}$	11000	11000	11000
	mm	115	115	125
	M	M14	M14	M14
	Kg	1.7	1.8	1.8
L_{PA}	dB(A)	88	89	89
L_{WA}	dB(A)	101	103	103
	m/s^2	4	4	4

EN60745, K = 3dB (L , L) K = 2,1 m/s2 (a)

This manual is consistent with the date of manufacture of your machine, you will find information on the technical data of the machine acquired manual check for updates of our machines on the website:

www.grupostayer.com

1 MACHINE-SPECIFIC SAFETY WARNINGS

1.1 SAFETY WARNINGS COMMON FOR GRINDING, SANDING, WIRE BRUSHING OR ABRASIVE CUTTING-OFF OPERATIONS

This power tool is intended to function as a grinder, sander, wire brush or cut-off tool. Read all safety warnings, instructions, illustrations and specifications provided with this power tool. Failure to follow all instructions listed below may result in electric shock, fire and/or serious injury.

This power tool is not recommended for polishing. Operations for which the power tool was not designed may create a hazard and cause personal injury.

Do not use accessories which are not specifically designed and recommended by the tool manufacturer. Just because the accessory can be attached to your power tool, it does not assure safe operation.

The rated speed of the accessory must be at least equal to the maximum speed marked on the power tool. Accessories running faster than their rated speed can break and fly apart.

The outside diameter and the thickness of your accessory must be within the capacity rating of your power tool. Incorrectly sized accessories cannot be adequately guarded or controlled.

The arbor size of wheels, flanges, backing pads or any other accessory must properly fit the spindle of the power tool. Accessories with arbor holes that do not match the mounting hardware of the power tool will run out of balance, vibrate excessively and may cause loss of control.

Do not use a damaged accessory. Before each use, inspect the accessory such as abrasive wheels for chips and cracks, backing pads for cracks, tears or excess wear, wire brushes for loose or cracked wires. If power tool or accessory is dropped, inspect for damage or install an undamaged accessory. After inspecting and installing an accessory, position yourself and bystanders away from the plane of the rotating accessory and run the power tool at maximum no-load speed for one minute. Damaged accessories will normally break apart during this test time.

Wear personal protective equipment. Depending on application, use face shield, safety goggles or safety glasses.

As appropriate, wear dust mask, hearing protectors, gloves and workshop apron capable of stopping small abrasive or workpiece fragments. The eye protection must be capable of stopping flying debris generated by various operations. The dust mask or respirator must be capable of filtering particles generated by your operation. Prolonged exposure to high intensity noise may cause hearing loss.

Keep bystanders a safe distance away from the work area. Anyone entering the work area must wear personal protective equipment. Fragments of workpiece or of a broken accessory may fly away and cause injury beyond immediate area of operation.

Hold the power tool only by the insulated gripping surfaces when performing an operation where the cutting accessory may contact hidden wiring or its own cord. Contact with a "live" wire will also make exposed metal parts of the power tool "live" and shock the operator.

Position the cord clear of the spinning accessory. If you lose control of the power tool, the cord may be cut or snagged and your hand or arm may be pulled into the spinning accessory. Never lay the power tool down until the accessory has come to a complete stop. The spinning accessory may grab the surface and pull the power tool out of your control.

Do not run the power tool while carrying it at your side. Accidental contact with the spinning accessory could snag your clothing, pulling the accessory into your body.

Regularly clean the power tool's air vents. The motor's fan will draw the dust inside the housing and excessive accumulation of powdered metal may cause electrical hazards.

Do not operate the power tool near flammable materials. Sparks could ignite these materials.

Do not use accessories that require liquid coolants. Using water or other liquid coolants may result in electrocution or shock.

1.2 KICKBACK AND RELATED WARNINGS

Kickback is a sudden reaction to a pinched or snagged rotating wheel, backing pad, brush or any other accessory. Pinching or snagging causes rapid stalling of the rotating accessory which in turn causes the uncontrolled power tool to be forced in the direction opposite of the accessory's rotation at the point of the binding. For example, if an abrasive wheel is snagged or pinched by the workpiece, the edge of the wheel that is entering into the pinch point can dig into the surface of the material causing the wheel to climb out or kick out. The wheel may either jump toward or away from the operator, depending on direction of the wheel's movement at the point of pinching. Abrasive wheels may also break under these conditions. Kickback is the result of power tool misuse and/or incorrect operating procedures or conditions and can be avoided by taking proper precautions as given below.

Maintain a firm grip on the power tool and position your body and arm to allow you to resist kickback forces.

Always use auxiliary handle, if provided, for maximum control over kickback or torque reaction during startup. The operator can control torque reactions or kickback forces, if proper precautions are taken.

Never place your hand near the rotating accessory. The accessory may kickback over your hand.

Do not position your body in the area where the power tool will move if kickback occurs. Kickback will propel the tool in the direction opposite to the wheel's movement at the point of snagging.

Use special care when working corners, sharp edges, etc. Avoid bouncing and snagging the accessory. Corners, sharp edges or bouncing have a tendency to snag the rotating accessory and cause loss of control or kickback.

Do not attach a saw chain woodcarving blade or toothed saw blade. Such blades create frequent kickback and loss of control over the power tool.

1.3 ADDITIONAL SAFETY INSTRUCTIONS FOR GRINDING AND CUTTING OFF OPERATIONS

Use only wheel types that are recommended for your power tool and the specific guard designed for the selected wheel. Wheels for which the power tool was not designed cannot be adequately guarded and are unsafe.

The guard must be securely attached to the power tool and positioned for maximum safety, so the least amount of wheel is exposed towards the operator. The guard helps to protect operator from broken wheel fragments and accidental contact with wheel.

Wheels must be used only for recommended applications. For example: do not grind with the side of the cut-off wheel. Abrasive cut-off wheels are intended for peripheral grinding; side forces applied to these wheels may cause them to shatter.

Always use undamaged wheel flanges that are of correct size and shape for your selected wheel. Proper wheel flanges support the wheel thus reducing the possibility of wheel breakage. Flanges for cut-off wheels may be different from grinding wheel flanges.

Do not use worn down wheels from larger power tools. Wheels intended for larger power tools are not suitable for the higher speed of a smaller tool and may burst.

1.4 ADDITIONAL SAFETY WARNINGS SPECIFIC FOR ABRASIVE CUTTING OFF OPERATIONS

Do not "jam" the cut-off wheel or apply excessive pressure. Do not attempt to make an excessive depth of cut. Overstressing the wheel increases the loading and susceptibility to twisting or binding of the wheel in the cut and the possibility of kickback or wheel breakage.

Do not position your body in line with and behind the rotating wheel. When the wheel, at the point of operation, is moving away from your body, the possible kickback may propel the spinning wheel and the power tool directly at you.

When wheel is binding or when interrupting a cut for any reason, switch off the power tool and hold the power tool motionless until the wheel comes to a complete stop. Never attempt to remove the cut-off wheel from the cut while the wheel is in motion, otherwise kickback may occur. Investigate and take corrective action to eliminate the cause of wheel binding.

Do not restart the cutting operation in the workpiece. Let the wheel reach full speed and carefully reenter the cut. The wheel may bind, walk up or kickback if the power tool is restarted in the workpiece.

Support panels or any oversized workpiece to minimize the risk of wheel pinching and kickback. Large workpieces tend to sag under their own weight. Supports must be placed under the workpiece near the line of cut and near the edge of the workpiece on both sides of the wheel.

Use extra caution when making a "pocket cut" into existing walls or other blind areas. The protruding wheel may cut gas or water pipes, electrical wiring or objects that can cause kickback.

1.5 SAFETY WARNINGS SPECIFIC FOR WIRE BRUSHING OPERATIONS

Be aware that wire bristles are thrown by the brush even during ordinary operation. Do not overstress the wires by applying excessive load to the brush. The wire bristles can easily penetrate light clothing and/or skin.

If the use of a guard is recommended for wire brushing, do not allow any interference of the wire wheel or brush with the guard. Wire wheel or brush may expand in diameter due to work load and centrifugal forces.

1.6 ADDITIONAL SAFETY WARNINGS



Wear safety goggles.

Use suitable detectors to determine if utility lines are hidden in the work area or call the local utility company for assistance. Contact with electric lines can lead to fire and electric shock. Damaging a gas line can lead to explosion. Penetrating a water line causes property damage or may cause an electric shock.

Release the On/Off switch and set it to the off position when the power supply is interrupted, e. g., in case of a power failure or when the mains plug is pulled. This prevents uncontrolled restarting.

When working stone, use dust extraction. The vacuum cleaner must be approved for the extraction of stone dust. Using this equipment reduces dust related hazards.

Use a cutting guide when cutting stone. Without sideward guidance, the cutting disc can jam and cause kickback.

When working with the machine, always hold it firmly with both hands and provide for a secure stance. The power tool is guided more secure with both hands.

Keep your workplace clean. Blends of materials are particularly dangerous. Dust from light alloys can burn or explode.

Never use the machine with a damaged cable. Do not touch the damaged cable and pull the mains plug when the cable is damaged while working. Damaged cables increase the risk of an electric shock.

2 FUNCTIONAL DESCRIPTION



Read all safety warnings and all instructions. Failure to follow the warnings and instructions may result in electric shock, fire and/or serious injury.

Secure the workpiece. A workpiece clamped with clamping devices or in a vice is held more secure than by hand.

2.1. INTENDED USE

The machine is intended for cutting, roughing, and brushing metal and stone materials without using water.

With approved sanding tools, the machine can be used for sanding with sanding discs.

2.2. PRODUCT FEATURES

The numbering of the product features refers to the illustration of the machine on the graphics page.

- 1 Release screw for protection guard
- 2 Spindle lock button
- 3 On/Off switch
- 4 Auxiliary handle
- 5 Grinder spindle
- 6 Protection guard for sanding
- 7 Mounting flange
- 8 Grinding/cutting disc
- 9 Clamping nut
- 10 Lock switch (SAB900RPS)
- 11 Long switch (SAB900RPS)

2.3. NOISE/VIBRATION INFORMATION

The values given are valid for nominal voltages [U] 230/240 V ~ 50/60 Hz - 110/120 V ~ 60Hz. For lower voltage and models for specific countries, these values can vary. Please observe the article number on the type plate of your machine. The trade names of the individual machines may vary.

We reserve the right to change related to technical advance.



= Rated input power



= N° of revolutions without load



= Maximum disk diameter



= Spindle thread



= Mass

Typical noise levels in evaluation A:



= Acceleration typically evaluated in the hand/arm

LPA = Acoustic pressure level

LWA = Acoustic power level

The noise level when working can exceed 85 dB (A).



Wear helmets hearing protection!

Measured values established in accordance with EN 60745.

The technical specifications set forth herein are understood within certain tolerances (In accordance with the present arrangements).

2.4. DECLARATION OF CONFORMITY

We declare under our sole responsibility that the product described under "Technical Data" is in conformity with the following standards or standardization documents:

EN 60745-1, EN 60745-2-3, EN 55014-1, EN 55014-2, EN 61000-3-2, EN 61000-3-3 according to the provisions of the directives 2006/42/CE, 2014/30/EU, 2011/65/EU.

Ramiro de la Fuente

Director General



CE  **RÓHS**

January 2018

3_ASSEMBLY

3.1. MOUNTING THE PROTECTIVE DEVICES



Before any work on the machine itself, pull the mains plug.

Protection Guard for Sanding

Place the protection guard 6 onto the spindle collar of the machine until the encoding keys of the protection guard agree with the spindle collar. Press and hold the release screw 1 while doing this.

Adjust the position of the protection guard 6 to the requirements of the work process. For this, release screw 1 upward and turn the protection guard 6 to the required position.

Adjust the protection guard 6 in such a manner that sparking is prevented in the direction of the operator.

The protection guard 6 may be turned only upon actuation of the release screw 1! Otherwise the power tool may not continue to be used under any circumstances and must be taken to an after-sales service agent.

Auxiliary Handle

Operate your machine only with the auxiliary handle 4.

Screw the auxiliary handle 4 on the right or left of the machine head depending on the working method.

3.2. MOUNTING THE GRINDING TOOLS



Before any work on the machine itself, pull the mains plug.

Grinding and cutting discs become very hot while working; do not touch until they have cooled.

Clean the grinder spindle 5 and all parts to be mounted. For clamping and loosening the grinding tools, lock the grinder spindle with the spindle lock button 2.

Actuate the spindle lock button only when the grinder spindle is at a standstill. Otherwise, the machine may become damaged.

Grinding/Cutting Disc

Pay attention to the dimensions of the grinding tools. The mounting hole diameter must fit the mounting flange without play. Do not use reducers or adapters.

When using diamond cutting discs, pay attention that the direction-of-rotation arrow on the diamond cutting disc and the direction of rotation of the machine (see direction-of-rotation arrow on the machine head) agree. (7→8→9)

See graphics page for the mounting sequence. To fasten the grinding/cutting disc, screw on the clamping nut 9 and tighten with the two-hole spanner.



After mounting the grinding tool and before switching on, check that the grinding tool is correctly mounted and that it can turn freely. Make sure that the grinding tool does not graze against the protection guard or other parts.

3.3. APPROVED GRINDING TOOLS

All grinding tools mentioned in these operating instructions can be used.

The permissible speed [rpm] or the circumferential speed [m/s] of the grinding tools used must at least match the values given in the table.

Therefore, observe the permissible rotational/circumferential speed on the label of the grinding tool.

máx					
[mm]	[mm]			[min ⁻¹]	[m/s]
D	b	d			

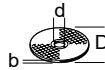

1156	22,2	11000	80
125	62	2,2	10500

3.4 DUST/CHIP EXTRACTION

Dusts from materials such as lead-containing coatings, some wood types, minerals and metal can be harmful to one's health. Touching or breathing-in the dusts can cause allergic reactions and/or lead to respiratory infections of the user or bystanders.

Certain dusts, such as oak or beech dust, are considered as carcinogenic, especially in connection with woodtreatment additives (chromate, wood preservative).

Materials containing asbestos may only be worked by specialists.

- Use dust extraction whenever possible.
- Provide for good ventilation of the working place.
- It is recommended to wear a P2 filterclass respirator.

Observe the relevant regulations in your country for the materials to be worked.

4_OPERATION

4.1.STARTING OPERATION

Observe correct mains voltage! The voltage of the power source must agree with the voltage specified on the nameplate of the machine. Power tools marked with 230 V can also be operated with 220 V.

When operating the machine with power from mobile generators that do not have sufficient reserve capacity or are not equipped with suitable voltage control with starting current amplification, loss of performance or untypical behavior can occur upon switching on.

Please observe the suitability of the power generator being used, particularly with regard to the mains voltage and frequency.

Switching On and Off

To start the power tool, push the On/Off switch 3 forwards.

To **lock** the On/Off switch 3, press the On/Off switch 3 down at the front until it latches.

To **switch off** the power tool, release the On/Off switch 3 or, if it is locked, briefly push down the back of the On/Off switch 3 and then release it.

Check grinding tools before using. The grinding tool must be mounted properly and be able to move freely. Carry out a test run for at least one minute with no load. Do not use damaged, out-of-centre or vibrating grinding tools. Damaged grinding tools can burst and cause injuries.

ON/ Off (SAB 900RPS)

For Start-up of power tool, push back the lock switch 10 and push the long switch 11, to disconnect the power tool, release the long switch 11.

4.2. WORKING ADVICE

- Exercise caution when cutting slots in structural walls; see Section "Information on Structures".
- Clamp the workpiece if it does not remain stationary due to its own weight.
- Do not strain the machine so heavily that it comes to a standstill.
- Grinding and cutting discs become very hot while working; do not touch until they have cooled.

Rough Grinding

Never use a cutting disc for roughing.

The best roughing results are achieved when setting the machine at an angle of 30° to 40°. Move the machine back and forth with moderate pressure. In this manner, the workpiece will not become too hot, does not discolour and no grooves are formed.

Cutting Metal

When cutting, work with moderate feed, adapted to the material being cut. Do not exert pressure onto the cutting disc, tilt or oscillate the machine.

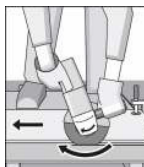

Do not reduce the speed of running down cutting discs by applying downward pressure.

The machine must always work in an upgrinding motion.

Otherwise, the danger exists of it being pushed uncontrolled out of the cut.

When cutting profiles and square bar, it is best to start at the smallest cross section.

Cutting Stone

The machine may be used only for dry cutting/grinding.

For cutting stone, it is best to use a diamond cutting disc. Switch on the machine and place the front part of the cutting guide on the workpiece.

Slide the machine with moderate feed, adapted to the material to be worked.

For cutting especially hard material, e. g., concrete with high pebble content, the diamond cutting disc can overheat and become damaged as a result. This is clearly indicated by circular sparking, rotating with the diamond cutting disc.

In this case, interrupt the cutting process and allow the diamond cutting disc to cool by running the machine for a short time at maximum speed with no load.

Noticeable decreasing work progress and circular sparking are indications of a diamond cutting disc that has become dull. Briefly cutting into abrasive material (e. g. lime-sand brick) can resharpen the disc again.

Information on Structures

Slots in structural walls are subject to the Standard DIN 1053 Part 1, or country-specific regulations.

These regulations are to be observed under all circumstances. Before beginning work, consult the responsible structural engineer, architect or the construction supervisor.

5. MAINTENANCE AND SERVICE

5.1. MAINTENANCE AND CLEANING

Before any work on the machine itself, pull the mains plug.

For safe and proper working, always keep the machine and ventilation slots clean.

In extreme working conditions, conductive dust can accumulate in the interior of the machine when working with metal. The protective insulation of the machine can be degraded. The use of a stationary extraction system is recommended in such cases as well as frequently blowing out the ventilation slots and installing a residual current device (RCD).

Please store and handle the accessory(-ies) carefully.

If the machine should fail despite the care taken in manufacturing and testing procedures, repair should be carried out by an after-sales service centre for Stayer power tools.

In all correspondence and spare parts order, please always include article number given on the type plate of the machine.

WARNING! Important instructions for connecting a new 3-pin plug to the 2-wire cable.

The wires in the cable are coloured according to the following code:

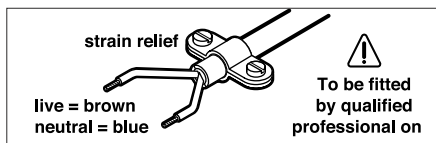

Do not connect the blue or brown wire to the earth terminal of the plug. Important: If for any reason the moulded plug is removed from the cable of this power tool, it must be disposed of safely.

5.2. AFTER-SALES SERVICE AND CUSTOMER ASSISTANCE

Our after-sales service responds to your questions concerning maintenance and repair of your product as well as spare parts. Exploded views and information on spare parts can also be found under:
www.grupostayer.com

Our customer consultants answer your questions concerning best buy, application and adjustment of products and accessories.

DISPOSAL

It is compulsory to subject electric tools, accessories and packaging to a recovery process that respect the environment.

For EU countries only:

Do not throw away electric tools!



In accordance with European Directive 2012/19/UE on unserviceable electric and electronic apparatus, after its transposition into national law, they must be collected separately to subject them to ecologic recycling.

The right to amendment is reserved.





STAYER

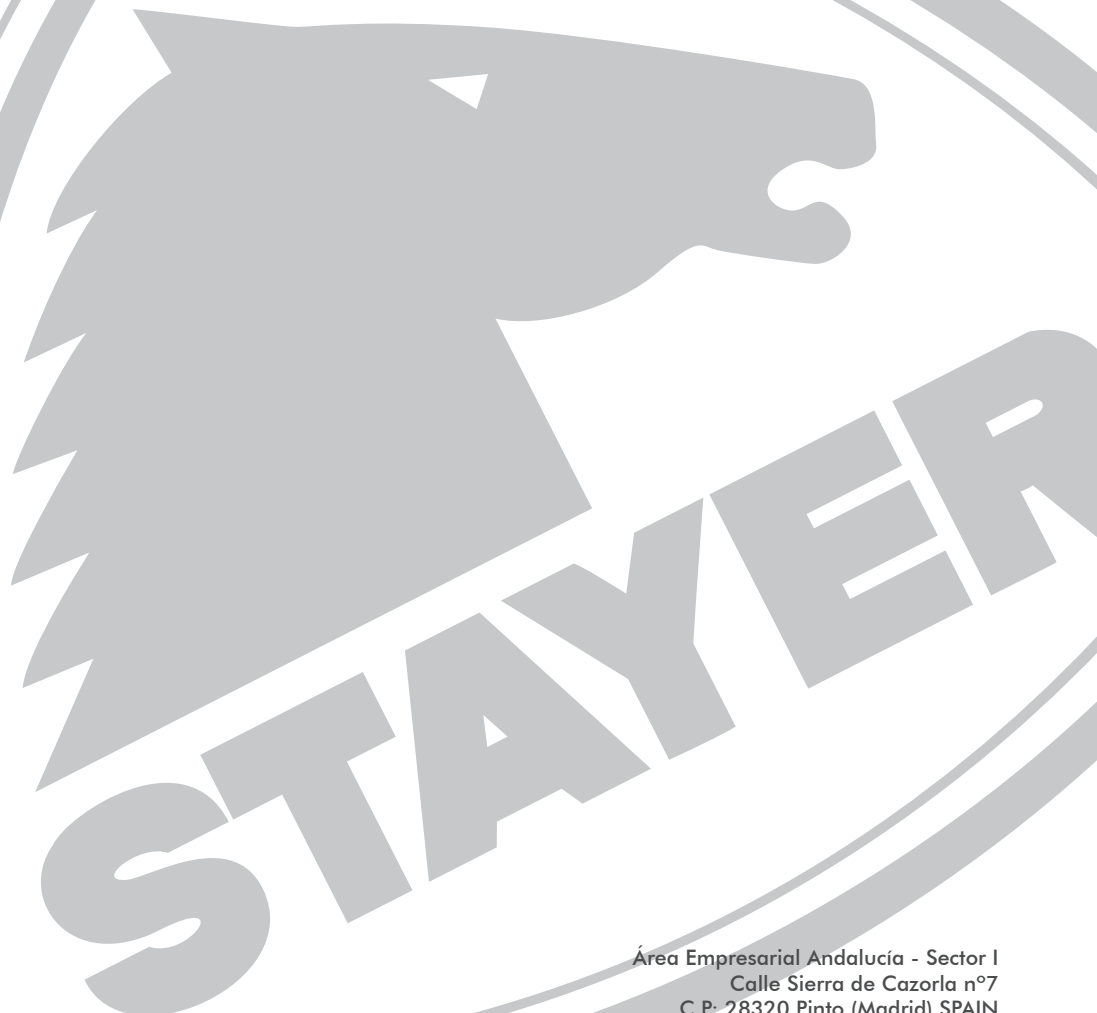

Área Empresarial Andalucía - Sector I
Calle Sierra de Cazorla nº7
C.P: 28320 Pinto (Madrid) SPAIN
info@grupostayer.com

www.grupostayer.com

